

HII-S

1000T-5000T

HII-S SERIES HIGH-END COLD CHAMBER
DIE CASTING MACHINE

High-performance Product Line Customized
for Global Markets

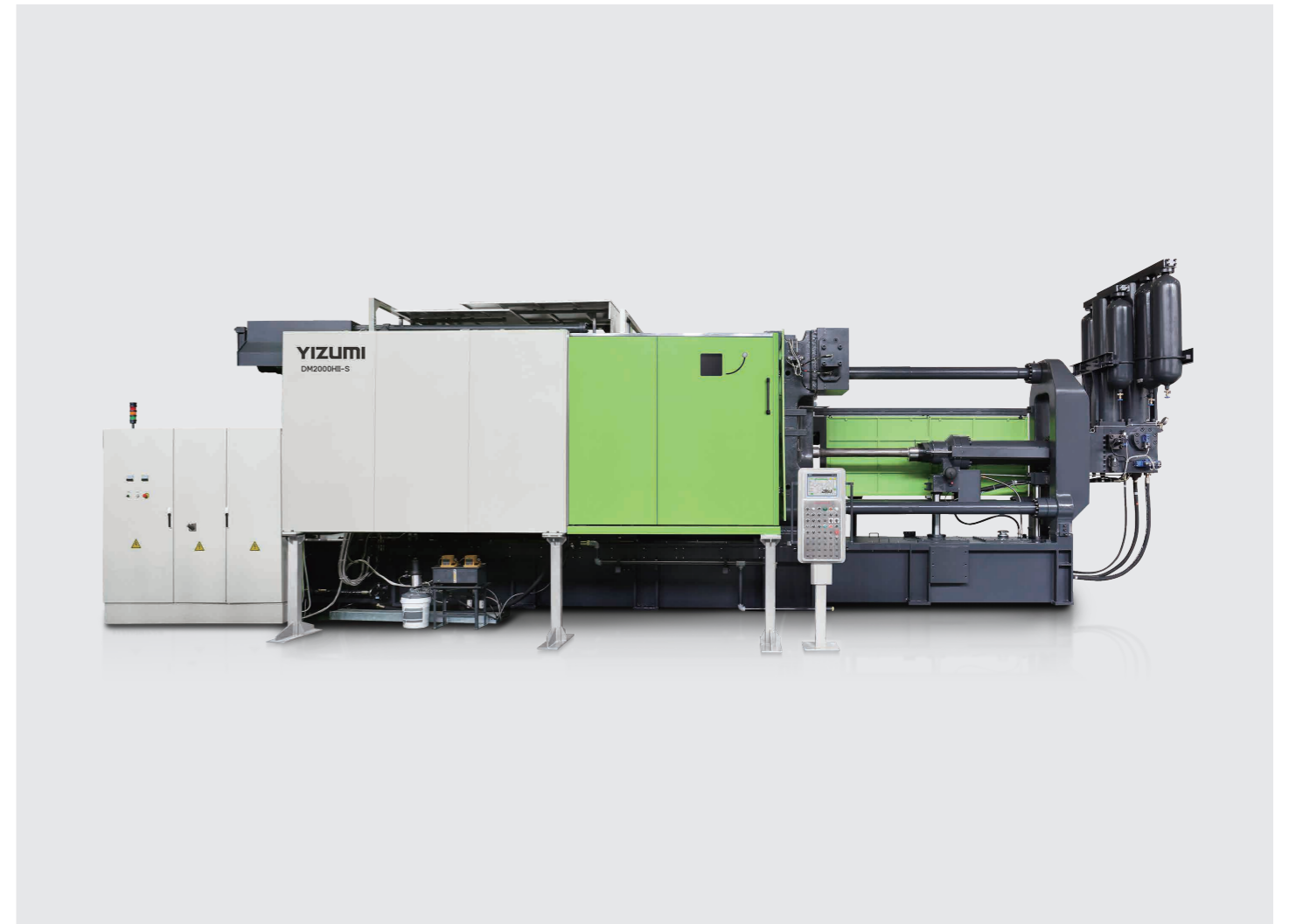

Yizumi Holdings Co., Ltd.

Address: No.22 Ke Yuan 3rd Road, Shunde, Foshan, Guangdong 528300, China
TEL: 86-757-2926 5301 86-757-2926 5300(overseas) Email: dcsolutions@yizumi.com
www.yizumi.com

[DISCLAIMER]

- [1] YIZUMI reserves the right to modify the product description in the catalogue. Specification might be changed without prior notice.
- [2] The picture in the catalogue is for reference only. The real object should be considered as final.
- [3] The data in the catalogue is obtained from internal testing in YIZUMI laboratory.
Please refer to the actual machine for the final data. YIZUMI reserves the right of final interpretation upon disputes and ambiguities.



THINK TECH FORWARD

HMS

PRODUCT DETAILS

PRODUCT DETAILS

YIZUMI connects with global advanced die-casting technology, introduces famous technology and process experts in die-casting field, and cooperates with local engineer team to integrate international advanced technical knowledge into our new die-casting machines.

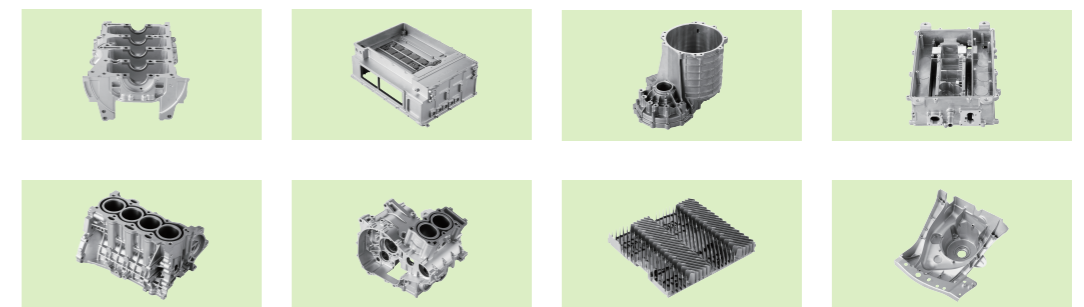

Heritage and Innovation for Our Customers

We at YIZUMI believe that accumulation and integration of technologies generates energy and inspires innovation and creativity. That is why we carefully synthesize century old knowledge of HPM (a YIZUMI brand) and state of the art German machine building technology with the YIZUMI experience of over 12000 die casting machines running worldwide.

This results in top technology solutions which are practical to use and benefit our customers with above- average productivity.

- ★ Guangdong Provincial Government Quality Award
- ★ Hi-tech Enterprise in Guangdong
- ★ Forbes Asia's Best Under A Billion 2018
- ★ One of the first national hi-tech enterprises
- ★ China Patent Excellence Award 2021
- ★ Key Enterprises of Strategic Emerging Industries in Guangdong Province (in the Field of Intelligent Manufacturing) in 2018
- ★ Top 500 Enterprises in Guangdong Province in 2019
- ★ Set up Post Doctoral Scientific Research Workstation and Academician Workstation

YIZUMI Germany

YIZUMI Germany was formally established in 2017 as our European R&D center for molding & casting technologies. Proximity to the renowned RWTH Aachen ensures constructive technological exchange on a high level.



Structural Casting Applications

Successful casting of structural applications in German OEM quality specification is one of the examples of the casting technology development done at the YIZUMI Research Center for Die Casting and Metal Molding.

Our customers can rely on Casting Technology solutions by YIZUMI.

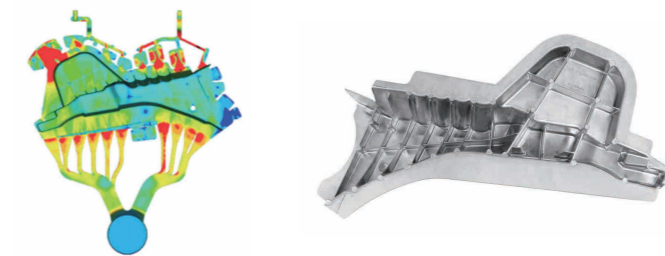

Focused R&D for Best Casting Results

The YIZUMI R&D team, in collaboration with our European experts, have introduced innovations with a clear focus on improved injection capability and performance. The result is an upgrade package providing significantly increased shot control precision and a high injection repeatability. These technological improvements strongly facilitate our customer's high performance manufacturing capability allowing them to successfully compete.

Application field

The HII-S series high-end cold chamber die casting machine is suitable for manufacturing non-ferrous metal die-casting products such as high-demand automobile and communication parts, high-precision 3C electronic parts, aviation and building materials parts, and household appliances.

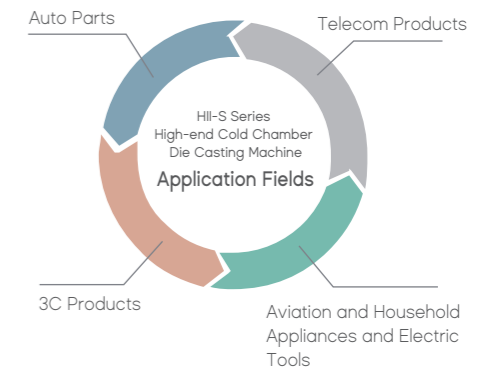

New, integrated Machine Development

HII-S Series High-end Cold Chamber Die Casting Machine

Precise and stable

Human centric HMI integrated in operation panel increases operational efficiency.

Significantly increased casting precision and a reduced pressure build-up time.

Top line acceleration and international-level process repeatability.

Efficient and durable

Re-engineered toggle system with increased rigidity improves productivity .

Optimized hydraulic drive design shortens cycle time and reduces energy consumption.

Modular machine design with HPM technology input for increased machine stability.

Wide range of application

Improved rigidity and design for every application.

Higher quality standards translate to lower operating cost.

Designed for longer machine service life.

Safe and reliable

Adheres to highest safety standards for our Customers.

Reliable casting production by HMI supported technology data display.

Integrated hydraulic ensures high performance output results.

User-friendly

Integrated easy-to-use machine design.

High quality international hardware components increase machine availability.

Excellent access for maintenance allow easy operation.

Modular design

Individually tested machine modules guarantee highest product quality.

Fully tested modules in inventory allow fast delivery of machines to customer.



New-generation Cold Chamber Die Casting Machine

Greatly Improved Injection Performance

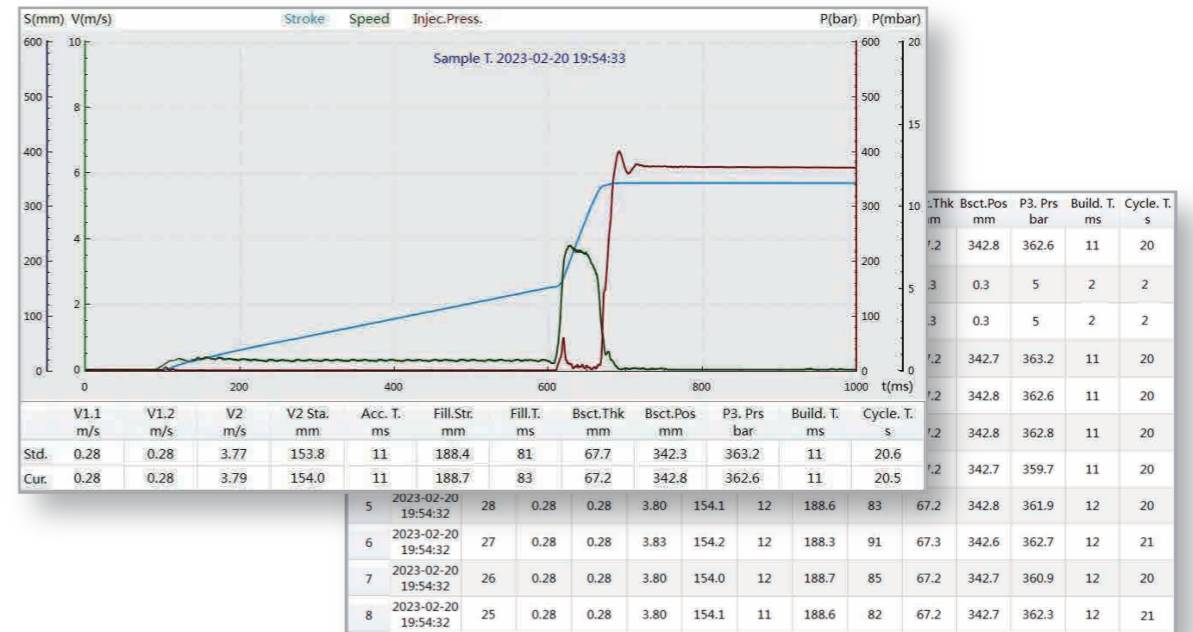
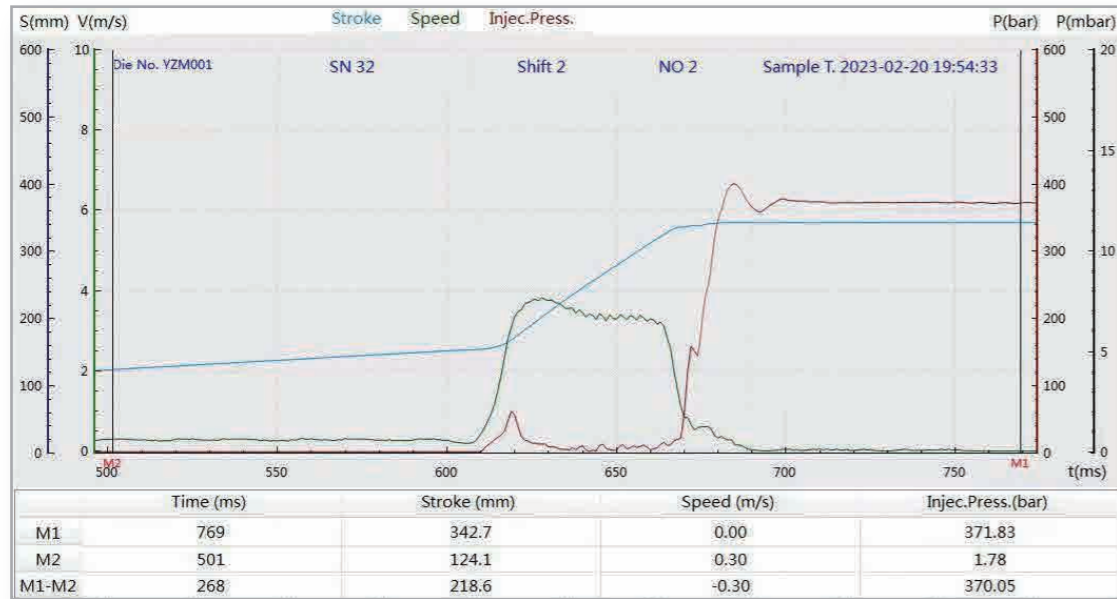

30%

Pressure build-up time shortened by 30%

Further improved pressure build-up time by over 30%. The H11-S pressure build-up time offers great performance to any casting process.

20%

Precision improved by 20%

The H11-S provides a high standard of precision to switch-over to the cavity filling phase. The deviation between setting and actual value is a mere ≤ 5 mm and a repeatability of ≤ 3 mm satisfies the highest requirements.



* Data above are reference criterions for factory tests.

Clamping Unit

Re-Engineered Clamping Unit

Shorter cycle time and increased platen rigidity significantly improve customers production output

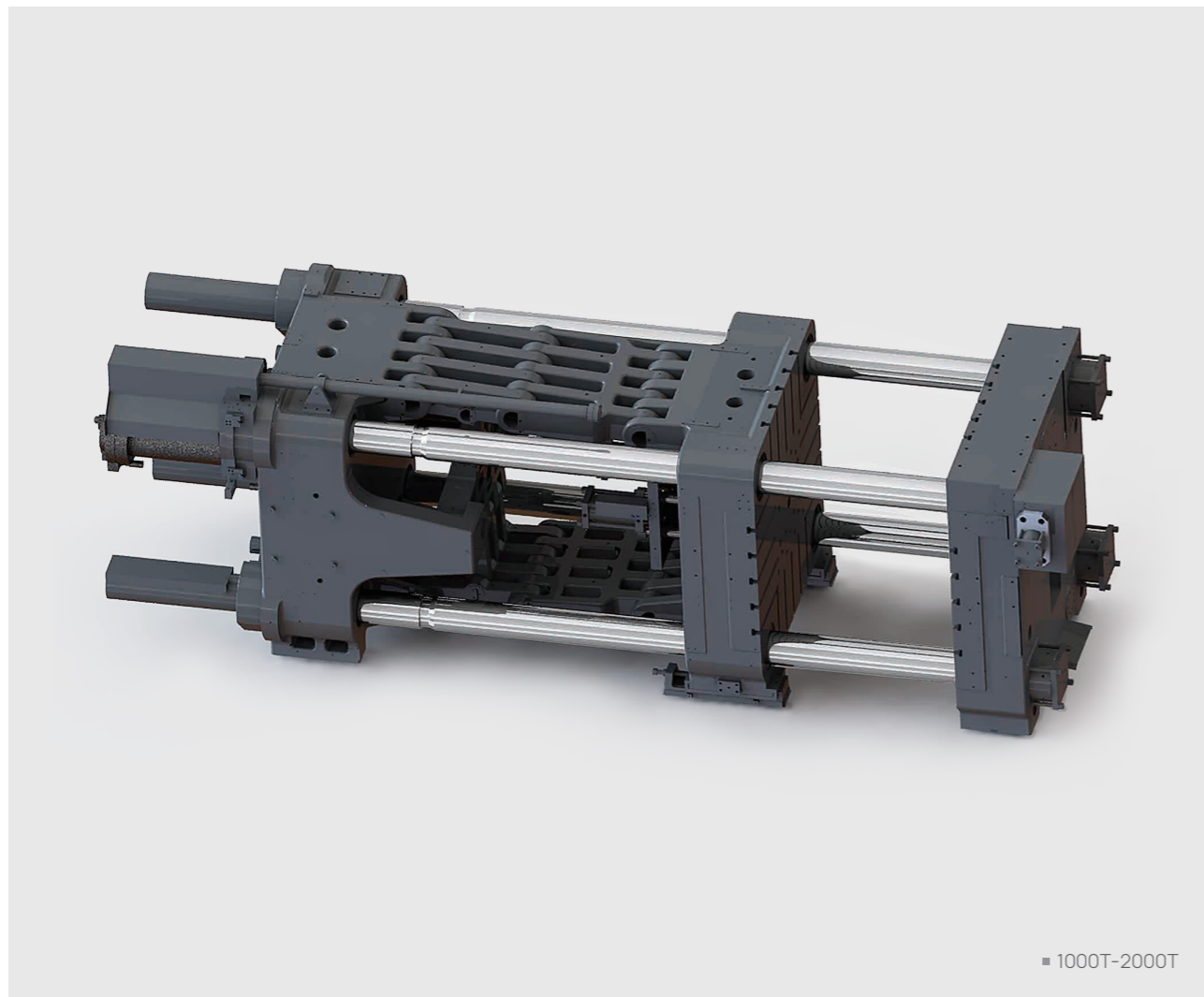

■ 1000T-2000T

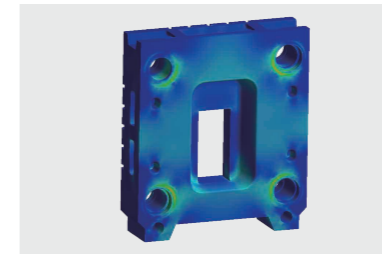

Re-Designed high rigidity platen

Further increased platen rigidity protects the die casting tools during operation. A new design based on FEM analysis offers an even distribution of force by minimized platen bending.

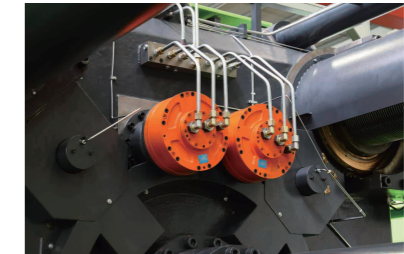

Auto die height adjustment

Ensuring stable locking forces during volume production, the auto die height adjustment supports a stable operation. Automatic re-adjustment of the target locking force during production start up offers further production efficiency.



Auto Position Die Height Adjustment

With well designed & rugged die height adjustment, it helps customers directly input the value, and the machine will automatically adjust the die height.



Adapt new material

The toggle pin holes are fitted with high-strength wear-resistant alloy bushes, which have excellent mechanical properties, are durable and have enhanced dry-running characteristics.

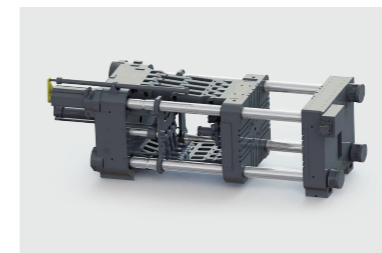

Six tie-bar design

Locking ends of 2500T and higher are designed in our six tie-bar-design which ensures efficient and smooth die closing and open movements for fastest machine cycle time.



Safety Operation

Further increased safety standards by added safety protection of the toggle area with sliding-doors to be opened individually for easy maintenance access.

* Data above are reference criterions for factory tests.

Upgraded Injection Unit

Increased casting process consistency for our customers based on successful international engineering cooperation.

Refined performance features include: Improved injection acceleration, shortened pressure building time, enhanced V2 starting position and repeatability.

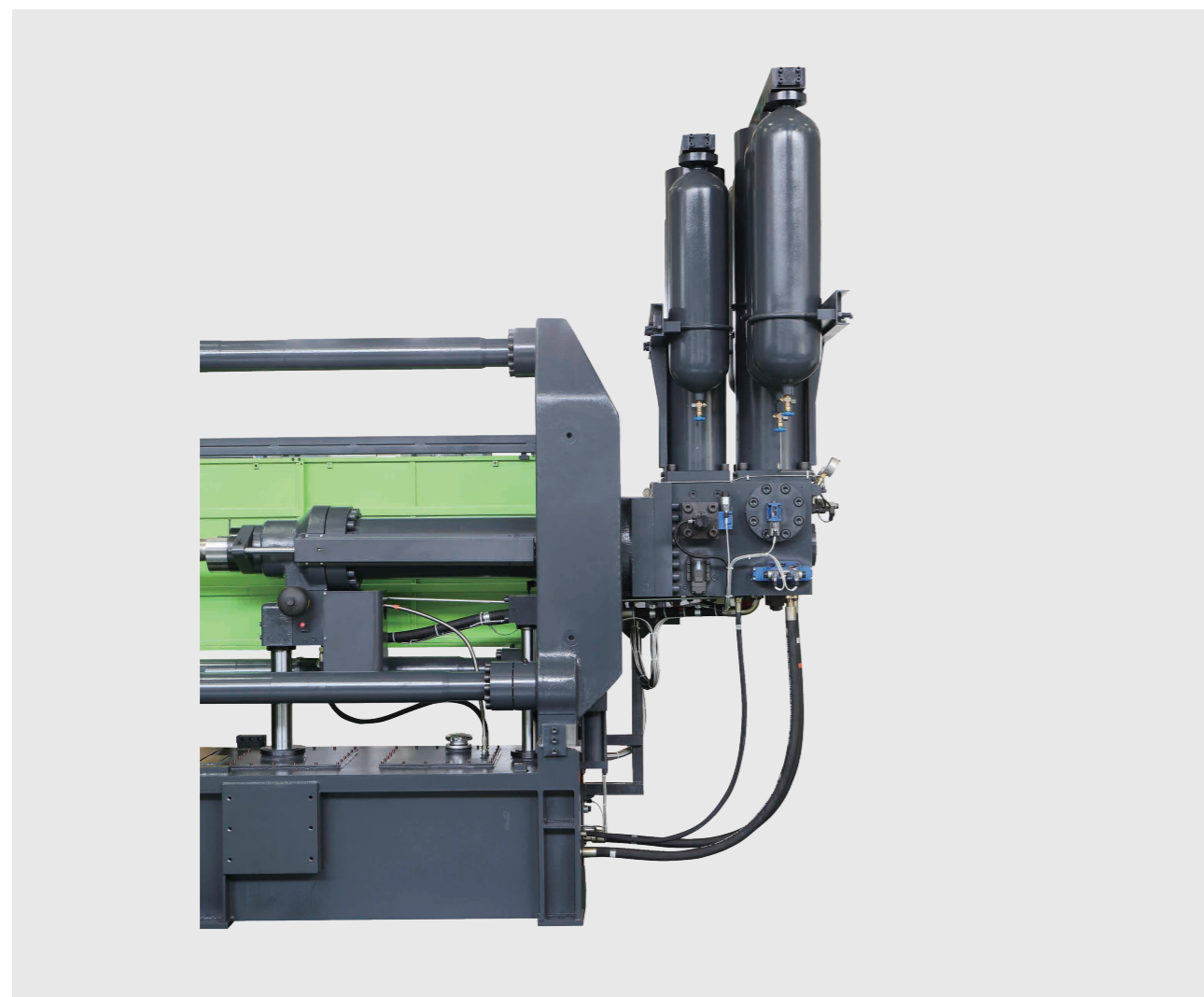

Hydraulic shot height adjustment

The new shot-height adjustment feature allows time-saving and easy adjustment of the injection position when setting up new dies.



Higher performance injection hydraulic system

A new integrated injection hydraulic improves injection performance and enhances casting process stability to reduce components and increase machine availability.



Spacer design for easy shot height adjustment

A smart system based on standardized spacer elements in the fixed platen allows adjustments of shot sleeve to any desired injection position.

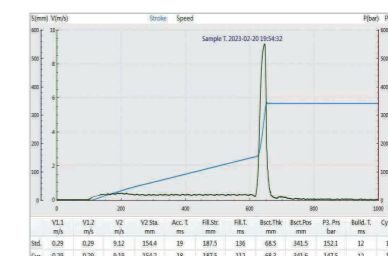

Enhanced shot performance

With its optimized hydraulic system, the HII-S system offers a high dry injection speed $\geq 8\text{m/s}$ ($\geq 10\text{m/s}$ is optional) and a high injection acceleration $\geq 40\text{G}$. In combination with its high-capacity P/Q performance, the HII-S die casting machine is built to provide high casting quality with even the most difficult parts.

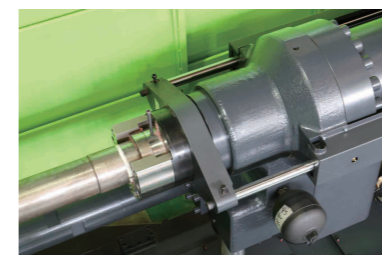

Highest stability of injection cylinder design

The proven YIZUZMI design featuring two guiding rods effectively avoids the rotation of the injection piston and ensures precise control and consistency of the injection.

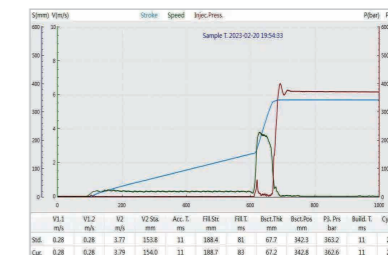

Optimized Pre-filling phase

Significantly improved hydraulic plunger movement in the pre-filling phase allow V1 process optimizations to prevent air entrapment in the shot sleeve.

* Data above are reference criterions for factory tests.

Fast and Precise Hydraulic Drive System

The hydraulic system precisely keeps the balance between energy consumption and efficiency to enable faster cycle times with minimal energy consumption. This effectively increase productivity to meet customers' higher OEE expectations.

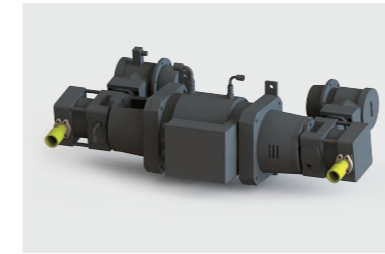
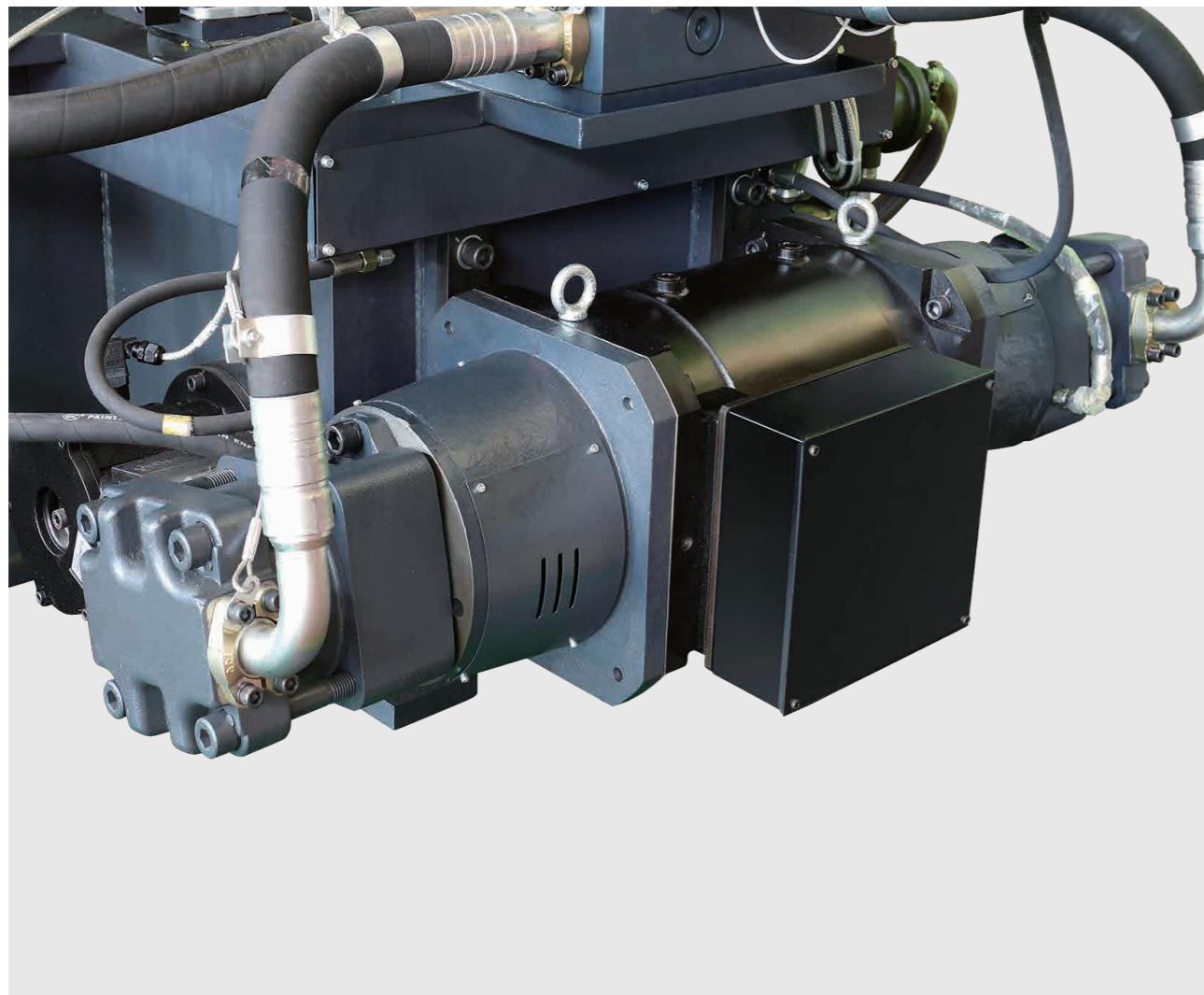

Modern servo drive system

The variability of the servo drive system provides higher oil capacity and a faster response time of the hydraulic machine movement. The result is a higher productivity at lower energy consumption.

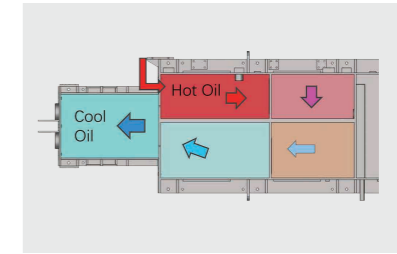

Optimized oil tank structure

An optimized interior structure of the oil tank improves heat dissipation and ensures effective management of oil quality and operating temperature. A design solution extends the service life of hydraulic components.



Additional personnel safety

High-pressure hydraulic hoses are equipped with steel hose-collars secured on wire-ropes. This additional safety feature effectively protects personnel.

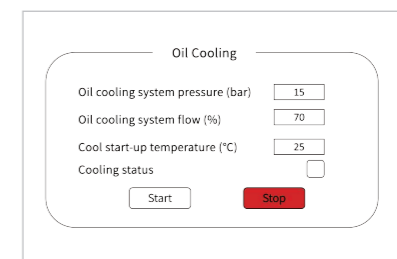

HII-S optimized cooling system

YIZUMI offers its customers a mature and stable servo drive solution with a separate oil filtering and effective cooling unit. This integrated, continuously improved solution ensures highest oil quality at best performance.

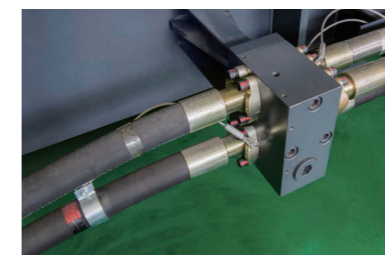

Optimized hydraulic piping

A smart combination of steel pipes and high -pressure hoses effectively ensures the reliability of the hydraulic system supporting a competitive OEE for our customers.

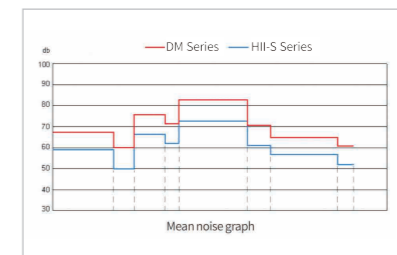

Less noise

The third generation servo drive offers even less noise emissions if compared to the previous design. System noise reduction of about 20%.

* Data above are reference criterions for factory tests.

International Standard Electrical Control System

High level design complying with worldwide safety standards.

Ensuring safe and precise control of the production process in an intelligent and convenient way.

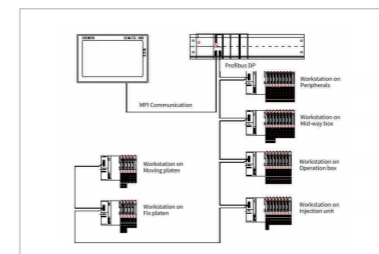

Standard protocol communication

Adhering to the design idea of reducing failure rates, the machine is equipped with a brand-new decentralized control system. Communication between the PLC and workstation relies on profibus DP. The system minimizes interferences by effectively lowering voltage loss at the components and facilitates quick troubleshooting ability, effectively reduce the voltage drop, easy to quickly find and repair.



Short-circuit protection

Newly developed core-pulling short-circuit protection with fast response and self-resetting function to ensure stable and high-yield operation of the machine.

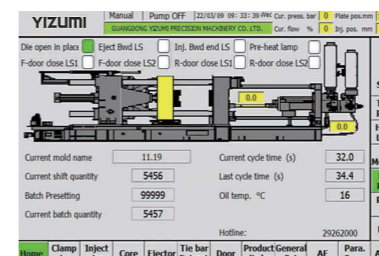

Optimized HMI

Further optimized layout and structure of our HMI increases flexibility in managing machine functions via a large touchscreen.

Intuitive and easy-to-understand maintenance functions such as maintenance tips, comprehensive alarm messages as well as operation guidance increase operational efficiency.

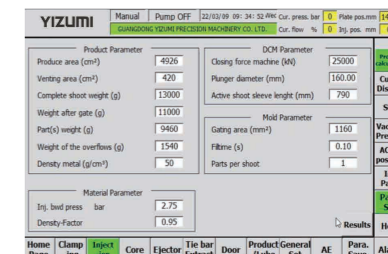

Technology Data Management & Calculation

Based on technology data input the YIZUMI HII-S control system calculates critical casting process data to support process engineers.

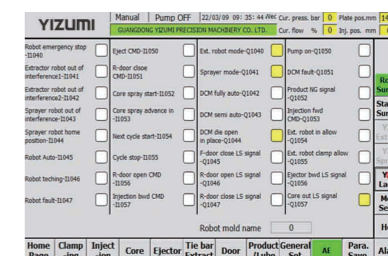

Cell Integration

The HII-S control system features standardized interfaces offering great flexibility in the choice of peripherals. Cell integration made easy.

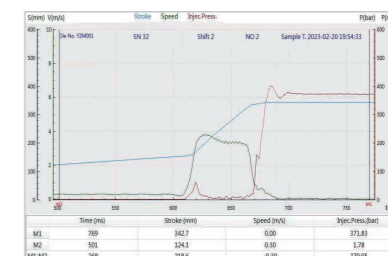

Intelligent online QC system

The YIZUMI QC package offers precise recording and display of the casting injection curves as well as monitoring of key casting process parameters including individual parameter tolerance settings. Casting Quality control made easy.

* Data above are reference criterions for factory tests.

Real-time Closed-loop Control (Optional)

YIZUMI Real Time Closed Loop Shot Control (RTCL) Highest standard of injection performance in real time.

RTCL on injection speed

Our enhanced RTCL shot control system ensures highest injection repeatability across all injection phases.

A reliable shot control from YIZUMI for advanced products and highest precision, including automatic correction of process parameters.

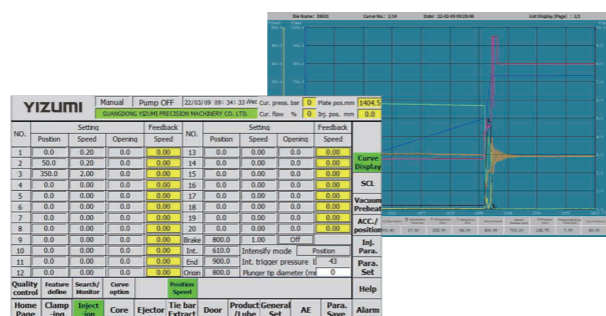

RTCL on injection speed & pressure

Real-time closed-loop control systems ensure quality consistency over long periods of time. Pressure, speed real-time detection and high-precision calibration enable a high degree of consistency in the customer's production process.

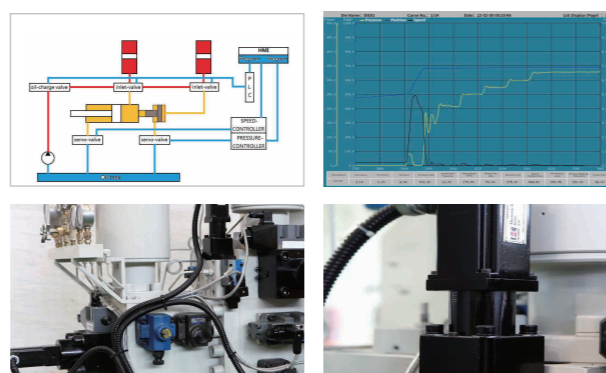

YIZUMI Condition Monitor System (Optional)

The Yi-CMS platform is a perfect addition to YIZUMI's modern die casting machines & cells. Our Yi-CMS provides all functions and connectivity needed to fully integrate YIZUMI cells as well as other machinery in an Industry 4.0 plant manufacturing system.

Machine Monitor

- The running status is viewed in real time
- Dynamic calculation of operational metrics
- Alarm information is collected in real time
- Timely warning of abnormal downtime

Process Monitor

- Process parameters are collected in real time
- Timely warning of parameter anomalies
- Historical processing parameters are traced
- Process parameters SPC control

Production Statistics

- Production progress monitoring
- Quality statistical analysis
- Hourly production statistics
- KPI exception alert



* Data above are reference criterions for factory tests.

* Data above are reference criterions for factory tests.

Research Center for Die Casting and Metal Molding

Yizumi Research Center for Die Casting and Metal Molding

Yizumi Gaoli plant has established Research Center for Die Casting and Metal Molding featuring a well equipped 3500T machine. The cell is equipped with an aluminum alloy dosing furnace incl. melt treatment with porous plugs, a high vacuum unit, a full set of mold thermoregulator unit (jet cooling, die temperature controller e.g.) and a whole set of robot automation unit. This infrastructure allows Yizumi Research Center for Die Casting and Metal Molding to meet the production demands of various large castings as well as structural castings.

Yizumi has created a real customer production environment, and can explore together with customers the core requirements of the die-casting process. Our aim is to provide a better and more satisfying equipment experience. Yizumi is working towards becoming the most cost-effective solution provider in the die-casting field.

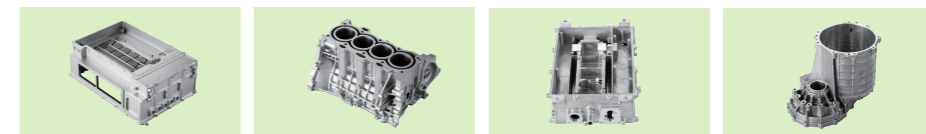

Yizumi Research Center 3500T Die Casting Cell

- Sprayer
- Ladler
- Part removal robot
- Air-cooling device
- Water-cooling device
- Pneumatic deslag device
- Dosing furnace
- Servo sawing device
- Safety fence
- Conveyor
- Vacuum machine
- Mold temperature controller
- Release agent mixing and feeding device
- Cylinder liner feed device
- Robotic polishing and deburring device
- Melting and holding furnace



Technical Data

ITEMS	UNIT	DM1000HII-S	DM1250HII-S	DM1650HII-S	DM2000HII-S	DM2500HII-S	DM3000HII-S	DM3500HII-S	DM4000HII-S	DM4500HII-S	DM5000HII-S
CLAMPING UNIT											
Locking Force	kN	10000	12500	16500	20000	25000	30000	35000	40000	45000	50000
Locking Stroke	mm	880	1000	1200	1400	1500	1500	1600	1800	1900	1900
Space Between Tie Bars	mm	1030x1030	1100x1100	1250x1250	1350x1350	1500x1500	1650x1650	1750x1750	1850x1850	1950x1950	1950x1950
Die Height (Min. - Max.)	mm	450-1100	450-1200	500-1400	600-1600	700-1800	800-2000	850-2000	900-2100	1100-2200	1100-2200
Ejector Force	kN	500	550	600	650	750	900	900	1100	1100	1100
Ejector Stroke	mm	200	200	250	300	300	300	300	400	400	400
INJECTION UNIT											
Injection Force	kN	850	1100	1300	1510	1700	2110	2410	2410	2800	2800
Injection Stroke	mm	850	910	970	1050	1100	1180	1400	1400	1600	1600
Plunger Diameter	mm	90-120	100-140	110-150	120-160	140-180	140-180	140-200	160-200	160-220	160-220
Injection Weight (Al)	kg	10-18	13-26	17-32	22-39	31-58	34-62	40-82	52-82	60-144	60-144
Casting Pressure (intensification)	Mpa	133-75	140-71	136-73	133-75	110-59	137-74	156-76	119-76	139-73	139-73
Casting Area	cm ²	748-1329	892-1748	1205-2240	1497-2660	2262-4167	2187-4029	2234-4560	3335-5210	3229-6105	3588-6784
Max. Casting Area (40MPa)	cm ²	2500	3125	4125	5000	6250	7500	8750	10000	11250	12500
Injection Position	mm	-100,-300	-160,-320	-175,-350	-200,-400	-200,-400	-250,-450	-300,-600	-300,-600	-300,-600	-300,-600
Plunger Penetration	mm	300	350	400	450	450	530	600	600	700	700
Casting Flange Diameter	mm	240	240	260	260	280	280	320	320	340	340
Casting Flange Protrusion	mm	20	25	25	30	30	30	35	35	35	35
OTHER											
Motor Capacity (SM)	kW	66.3	81.7	94.2	137.8	163.4	188.4	152.8	176.8	176.8	176.8
System Working Pressure	Mpa	16	16	16	16	16	16	21	21	21	21
Oil Tank Capacity	L	1750	2000	2100	3100	4350	4800	4000	4800	4800	4800
Machine Dimension (Lx Wx H)	mm	10400x3900x4100	11800x4010x4200	12800x4380x4300	13500x4790x4450	15400x6110x4600	15600x6110x4650	16000x6200x4900	17000x6650x5650	17600x6650x5750	17600x6650x5750

* Data above are reference criterions for factory tests.

Remark : We reserve the right to make any product improvement or specifications change without prior notice.
Any product photos shown in catalogue are for future reference only.

Standard and Optional Features

ITEMS	DM1000HII-S	DM1250HII-S	DM1650HII-S	DM2000HII-S	DM2500HII-S	DM3000HII-S	DM3500HII-S	DM4000HII-S	DM4500HII-S	DM5000HII-S
General										
Machine standard color *	●	●	●	●	●	●	●	●	●	●
Customer specified color	○	○	○	○	○	○	○	○	○	○
Electrical and floor mounted safety door (left)	●	●	●	●	●	●	●	●	●	●
Electrical and floor mounted safety door (right)	●	●	●	●	●	●	●	●	●	●
Toggle safety door (left,right)	●	●	●	●	●	●	●	●	●	●
Electrical System										
15" touch screen	●	●	●	●	●	●	●	●	●	●
Air conditioner	●	●	●	●	●	●	●	●	●	●
Mould parameters storage(100 sets)	●	●	●	●	●	●	●	●	●	●
Extended mould parameters storage	○	○	○	○	○	○	○	○	○	○
Electronic locking force display	○	○	○	○	○	○	○	○	○	○
Clamping System										
Dual proportional control of die open and close	●	●	●	●	●	●	●	●	●	●
Magnetic tape for stroke control	●	●	●	●	●	●	●	●	●	●
DDC system	●	●	●	●	●	●	●	●	●	●
Die height adjustment control- position	●	●	●	●	●	●	●	●	●	●
Die height adjustment control-position and force	○	○	○	○	○	○	○	○	○	○
Central toggle system lubrication	●	●	●	●	●	●	●	●	●	●
Central die height system lubrication	●	●	●	●	●	●	●	●	●	●
Hydraulic tie bar extraction (left & top)	●	●	●	●	●	●	●	●	●	●
Hydraulic tie bar extraction (right & top)	○	○	○	○	○	○	○	○	○	○
Hydraulic System										
Servo motor system	●	●	●	●	●	●	●	●	●	●
Core and Ejector										
Dual proportional control	●	●	●	●	●	●	●	●	●	●
2 set on moving platen	●	●	●	●	●	●	●	●	●	●
Customized core numbers on moving platen	○	○	○	○	○	○	○	○	○	○
2 set on fix platen	●	●	●	●	●	●	●	●	●	●
Customized core numbers on fix platen	○	○	○	○	○	○	○	○	○	○
Squeezing function for core-pulling	●	●	●	●	●	●	●	●	●	●
Ejector stroke control - magnetic tape	●	●	●	●	●	●	○	○	○	○
Ejector stroke control - limit switch	○	○	○	○	○	○	●	●	●	●
Injection System										
Injection proportional control	●	●	●	●	●	●	●	●	●	●
Injection stroke control - magnetic tape	●	●	●	●	●	●	●	●	●	●
Intelligent online PPS technology	●	●	●	●	●	●	●	●	●	●
RTCL control - speed	○	○	○	○	○	○	○	○	○	○
RTCL control - speed & pressure	○	○	○	○	○	○	○	○	○	○
Others										
Oil temperture indiacator	●	●	●	●	●	●	●	●	●	●
Electronic oil temperature alarm	●	●	●	●	●	●	●	●	●	●
Plunger lubrication system	○	○	○	○	○	○	○	○	○	○

*: RAL9003, RAL120 70 75, RAL7021

● Standard feature ○ Optional feature

Platen Dimension Drawings

DM1000HII-S

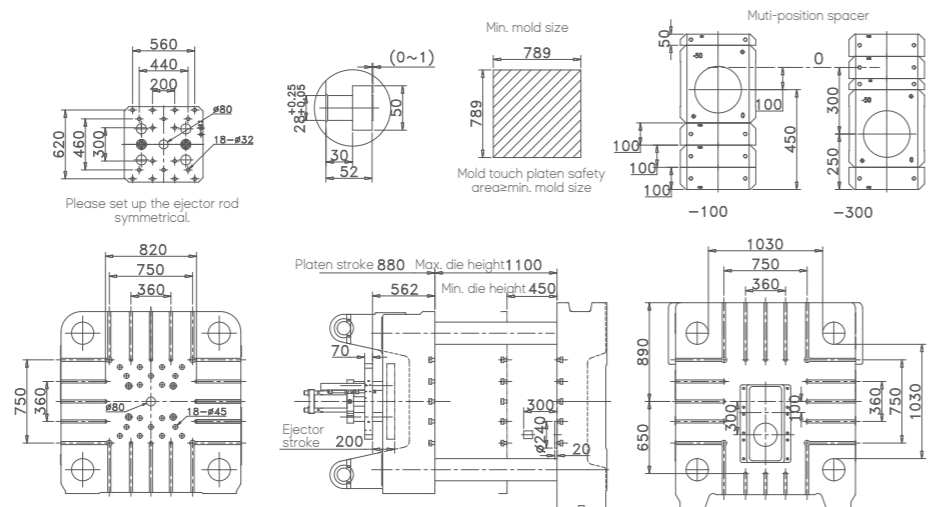

DM2000HII-S

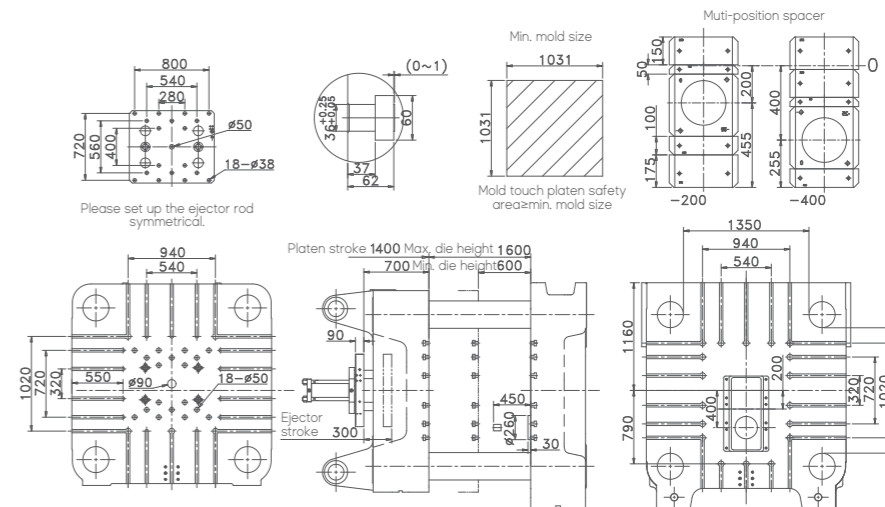

DM1250HII-S

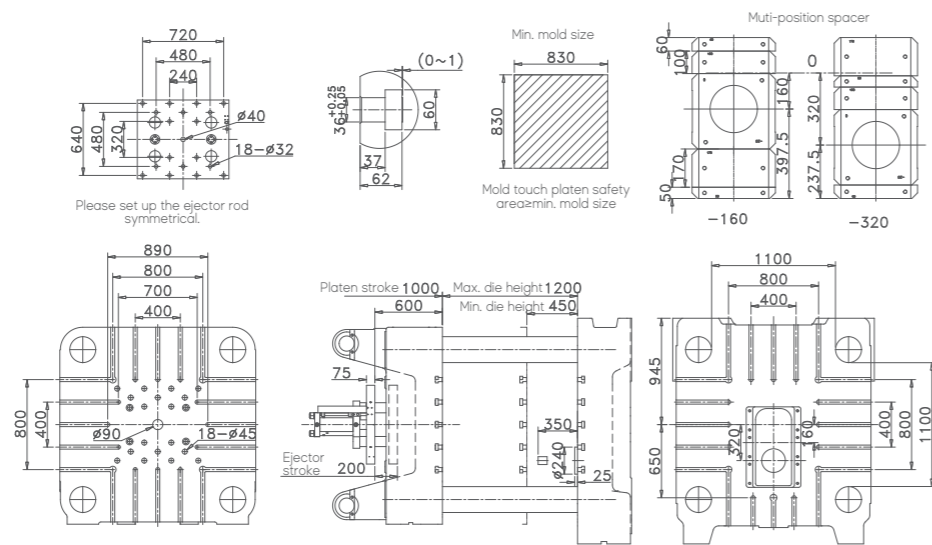

DM2500HII-S

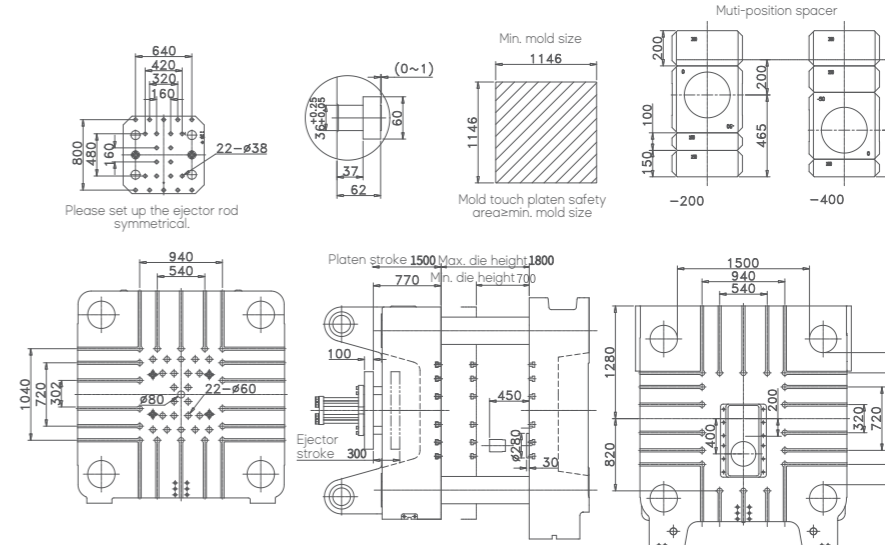

DM1650HII-S

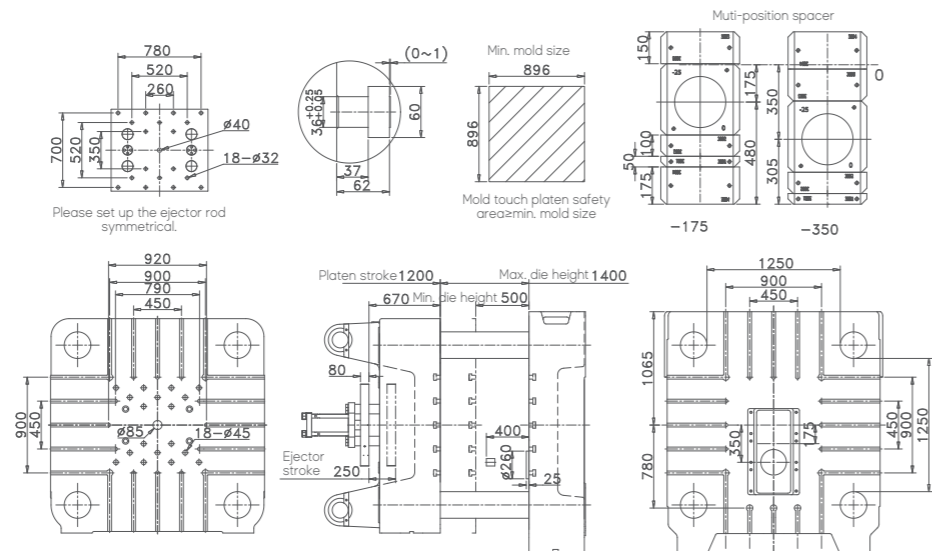

DM3000HII-S

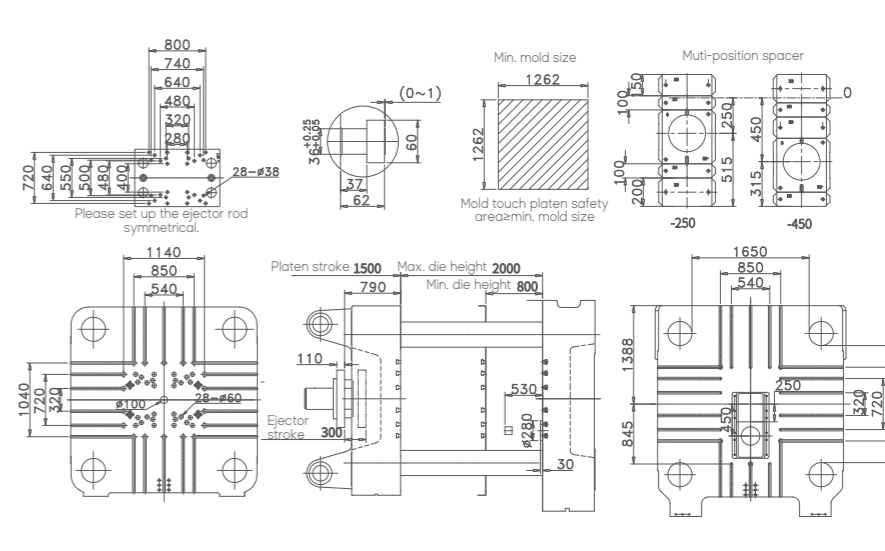

Platen Dimension Drawings

DM3500HII-S

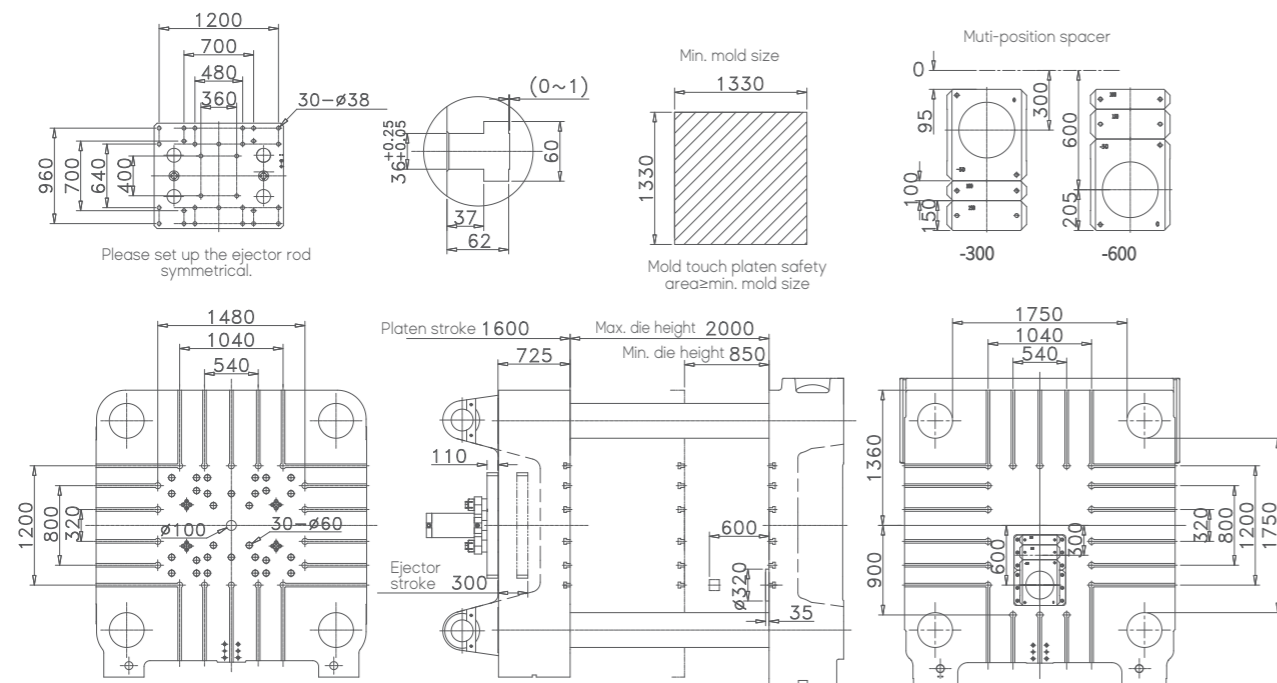

DM4500HII-S

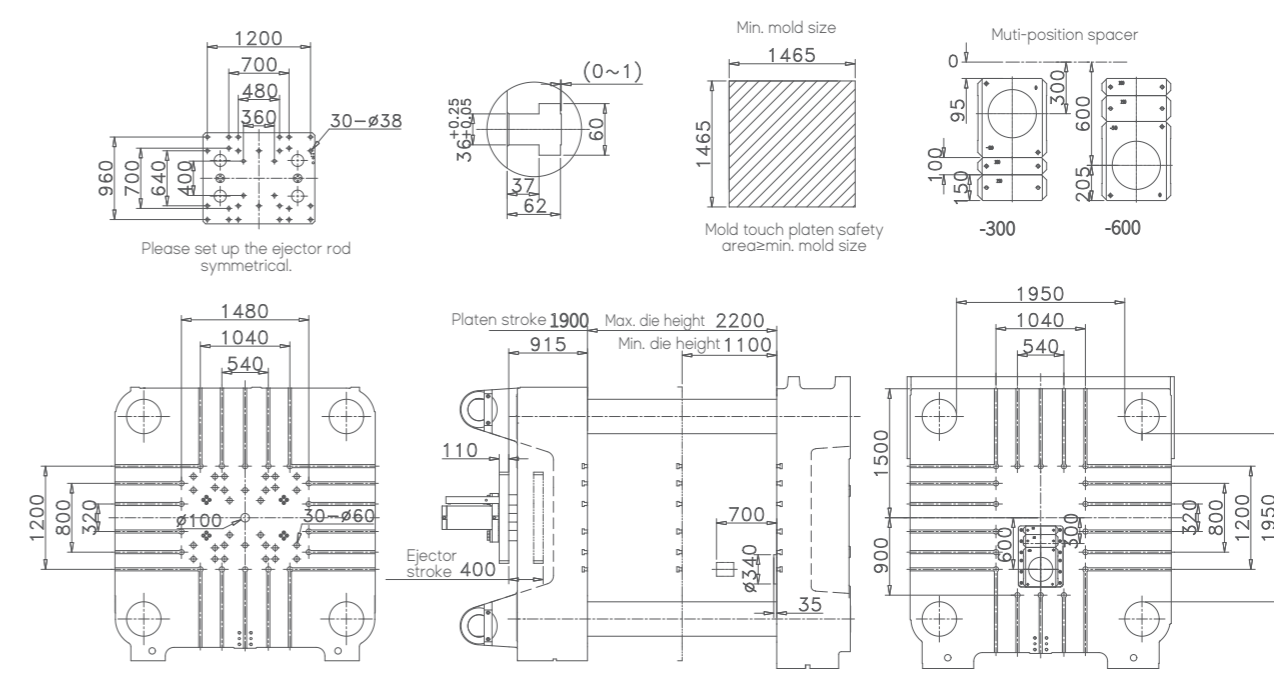

DM4000HII-S

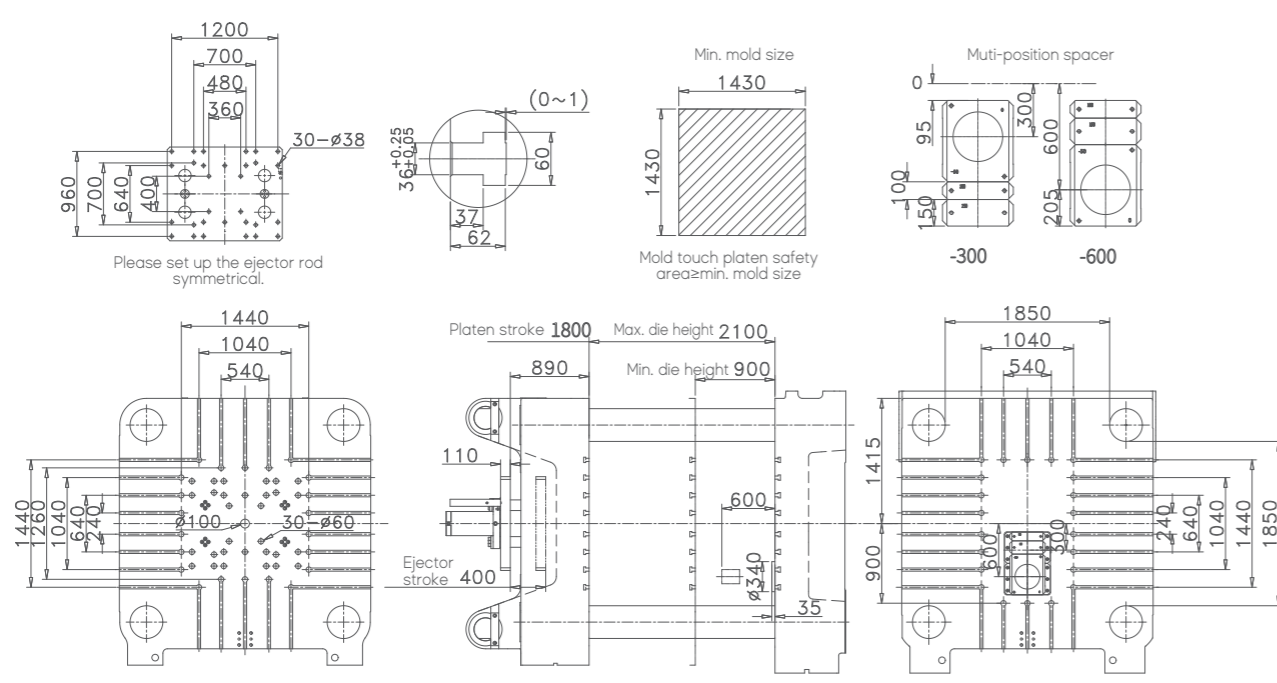

DM5000HII-S

