

# HII-S

## 180T-900T

HII-S SERIES HIGH-END COLD CHAMBER  
DIE CASTING MACHINE

High-performance Product Line Customized  
for Global Markets



**Yizumi Holdings Co., Ltd.**

Address: No.22 Ke Yuan 3rd Road, Shunde, Foshan, Guangdong 528300, China  
TEL: 86-757-2926 5301 86-757-2926 5300(overseas) Email: dcsolutions@yizumi.com  
www.yizumi.com

**[DISCLAIMER]**

- [1] YIZUMI reserves the right to modify the product description in the catalogue. Specification might be changed without prior notice.
- [2] The picture in the catalogue is for reference only. The real object should be considered as final.
- [3] The data in the catalogue is obtained from internal testing in YIZUMI laboratory.  
Please refer to the actual machine for the final data. YIZUMI reserves the right of final interpretation upon disputes and ambiguities.



THINK TECH FORWARD

# PRODUCT DETAILS

## PRODUCT DETAILS

YIZUMI connects with global advanced die-casting technology, introduces famous technology and process experts in die-casting field, and cooperates with local engineer team to integrate international advanced technical knowledge into our new die-casting machines.

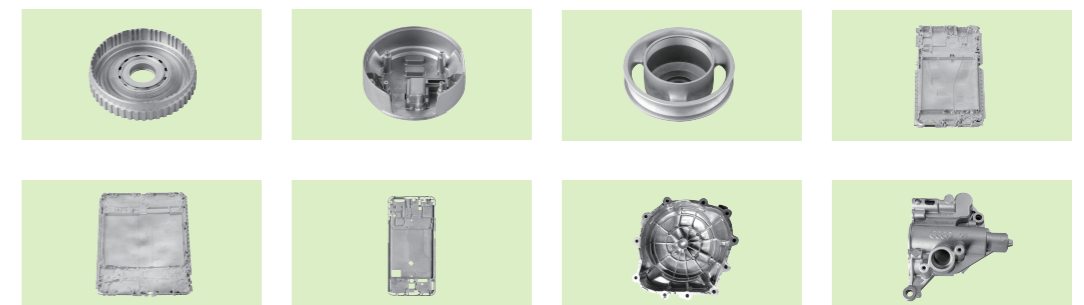

## Heritage and Innovation for Our Customers

We at YIZUMI believe that accumulation and integration of technologies generates energy and inspires innovation and creativity. That is why we carefully synthesize century old knowledge of HPM (a YIZUMI brand) and state of the art German machine building technology with the YIZUMI experience of over 12000 die casting machines running worldwide.

This results in top technology solutions which are practical to use and benefit our customers with above- average productivity.

- ★ Guangdong Provincial Government Quality Award
- ★ Hi-tech Enterprise in Guangdong
- ★ Forbes Asia's Best Under A Billion 2018
- ★ One of the first national hi-tech enterprises
- ★ China Patent Excellence Award 2021
- ★ Key Enterprises of Strategic Emerging Industries in Guangdong Province (in the Field of Intelligent Manufacturing) in 2018
- ★ Top 500 Enterprises in Guangdong Province in 2019
- ★ Set up Post Doctoral Scientific Research Workstation and Academician Workstation

### YIZUMI Germany

YIZUMI Germany was formally established in 2017 as our European R&D center for molding & casting technologies. Proximity to the renowned RWTH Aachen ensures constructive technological exchange on a high level.



### Structural Casting Applications

Successful casting of structural applications in German OEM quality specification is one of the examples of the casting technology development done at the YIZUMI Research Center for Die Casting and Metal Molding.

Our customers can rely on Casting Technology solutions by YIZUMI.

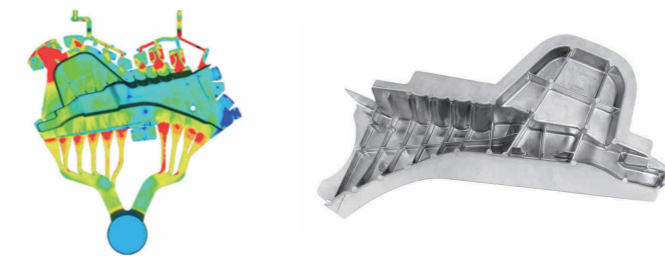

### Focused R&D for Best Casting Results

The YIZUMI R&D team, in collaboration with our European experts, have introduced innovations with a clear focus on improved injection capability and performance. The result is an upgrade package providing significantly increased shot control precision and a high injection repeatability. These technological improvements strongly facilitate our customer's high performance manufacturing capability allowing them to successfully compete.

### Application field

The HII-S series high-end cold chamber die casting machine is suitable for manufacturing non-ferrous metal die-casting products such as high-demand automobile and communication parts, high-precision 3C electronic parts, aviation and building materials parts, and household appliances.

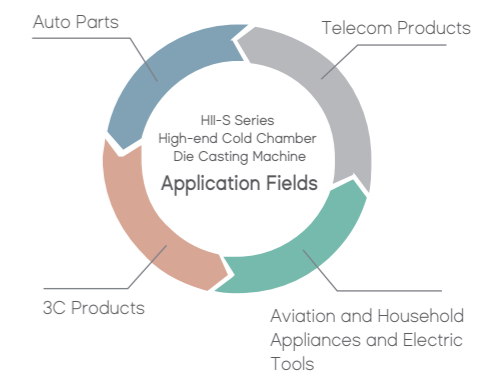

New, integrated Machine Development

## HII-S Series High-end Cold Chamber Die Casting Machine

### Precise and stable

Human centric HMI integrated in operation panel increases operational efficiency.

Significantly increased casting precision and a reduced pressure build-up time.

Top line acceleration and international-level process repeatability.

### Efficient and durable

Re-engineered toggle system with increased rigidity improves productivity .

Optimized hydraulic drive design shortens cycle time and reduces energy consumption.

Modular machine design with HPM technology input for increased machine stability.

### Wide range of application

Improved rigidity and design for every application.

Higher quality standards translate to lower operating cost.

Designed for longer machine service life.

### Safe and reliable

Adheres to highest safety standards for our Customers.

Reliable casting production by HMI supported technology data display.

Integrated hydraulic ensures high performance output results.

### User-friendly

Integrated easy-to-use machine design.

High quality international hardware components increase machine availability.

Excellent access for maintenance allow easy operation.

### Modular design

Individually tested machine modules guarantee highest product quality.

Fully tested modules in inventory allow fast delivery of machines to customer.



New-generation Cold Chamber Die Casting Machine

# Greatly Improved Injection Performance

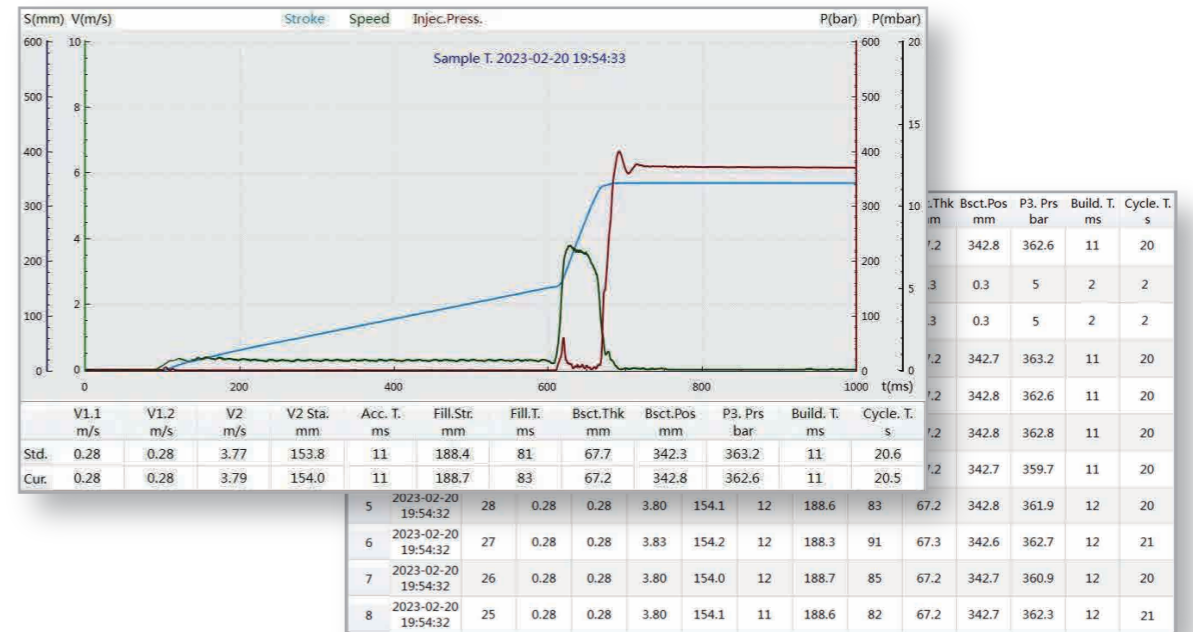
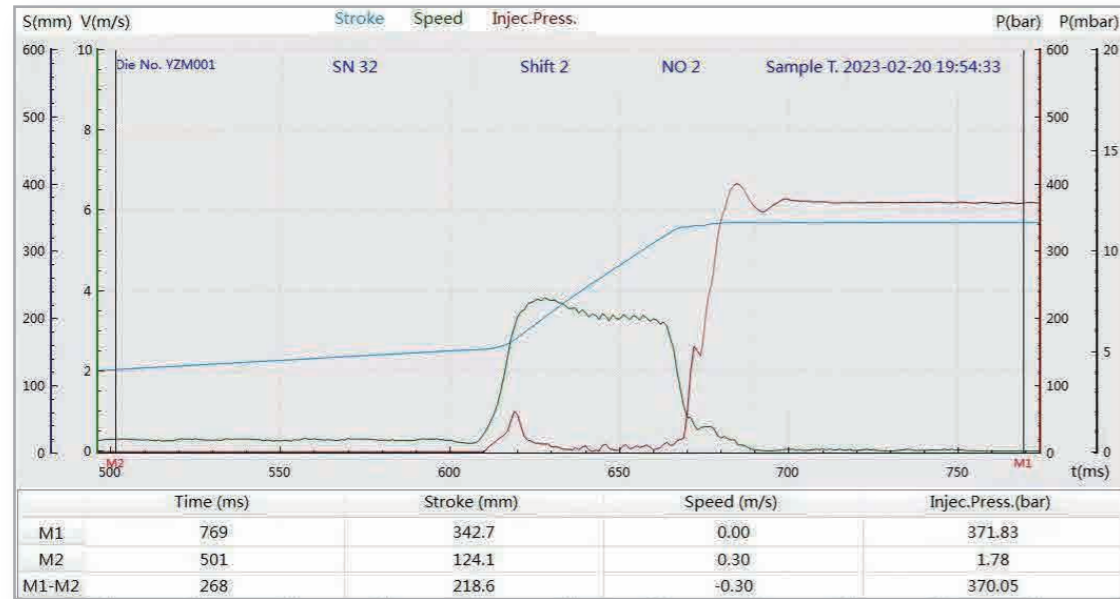

# 30%

Pressure build-up time shortened by 30%

Further improved pressure build-up time by over 30%. The HII-S pressure build-up time offers great performance to any casting process.

# 20%

Precision improved by 20%

The HII-S provides a high standard of precision to switch-over to the cavity filling phase. A repeatability of max +/-2mm satisfies the highest requirements.



\* Data above are reference criterions for factory tests.



# Upgraded Injection Unit

Increased casting process consistency for our customers based on successful international engineering cooperation.

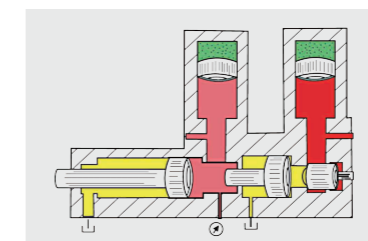

## Enhanced shot performance

With its optimized hydraulic system, the HII-S system offers a high injection acceleration of up to 50G. In combination with its high-capacity P/Q<sup>2</sup> performance, the HII-S die casting machine is built to provide high casting quality with even the most difficult parts.

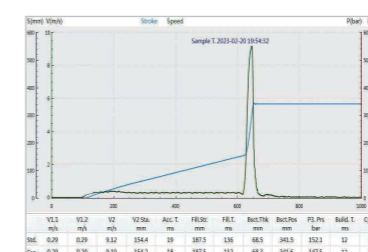

## High precision & repeatable switch-over to fast filling phase

The max. injection speed of up to 9 m/s (up to 10 m/s is optional) meets customer's high process requirements.



## Higher performance injection hydraulic system

A new integrated injection hydraulic adds injection performance to improve casting process stability while reducing components and increasing machine availability.

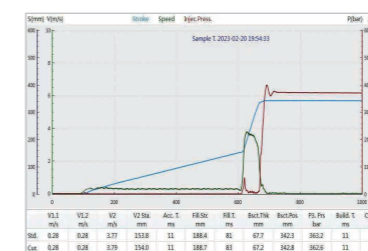

## High precision control

Precisely triggering the fast-filling phase is critical for many die casting applications. The HII-S provides a high standard of precision to switch-over to the cavity filling phase. The deviation is ≤5mm. A repeatability of max +/-2mm which satisfies the highest requirements.

\* Data above are reference criterions for factory tests.



# Fast and Precise Hydraulic Drive System

The hydraulic system precisely keeps the balance between energy consumption and efficiency to enable faster cycle times with minimal energy consumption. This effectively increase productivity to meet customers' higher OEE expectations.



## The Third-generation Servo System



### Less Noise

The third generation servo drive offers even Less noise emissions if compared to the previous design. System noise reduction of about 20%.

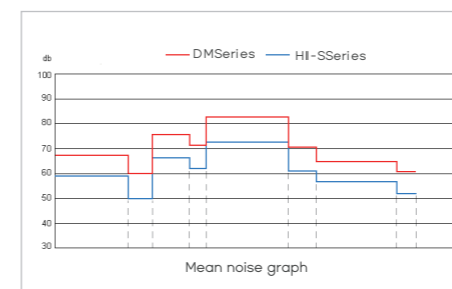

### Enhanced Power

Stabilizing power surges automatically for up to 5 mins, this system offers great operational stability even with fluctuating main power.

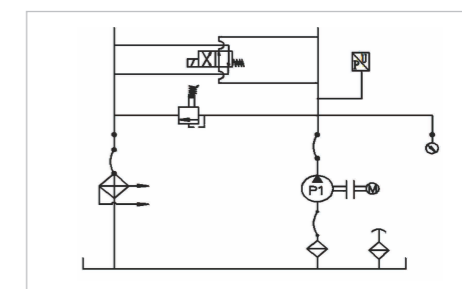

### Faster Response Time

Reduced system response time improves reaction time and the highest operational performance.

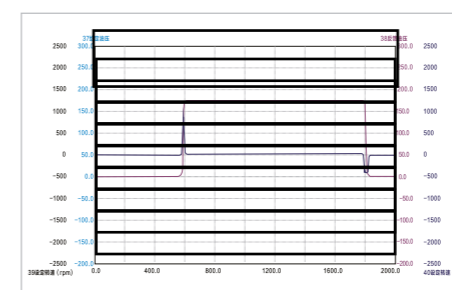

### Energy Saving

This efficient servo pump system ensures the lowest possible oil temperatures, further enhancing operational efficiency.

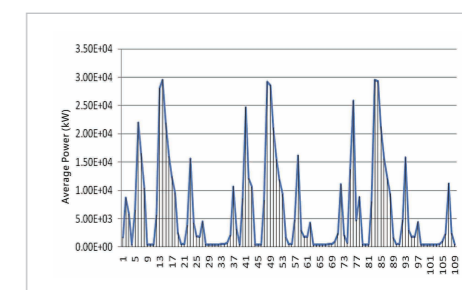

\* Data above are reference criterions for factory tests.

# International Standard Electrical Control System

High level design complying with worldwide safety standards .



## New integrated Operating panel with HMI

The integrated operating panel is easy to use and saves time for the operator as well as the casting process engineers.

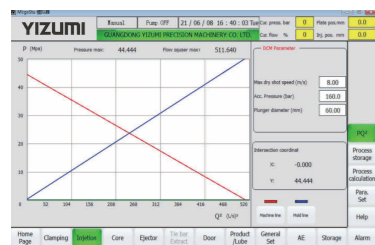

## Technology Data Management & Calculation

Based on technology data input the YIZUMI HII-S control system calculates critical casting process data to support process engineers.

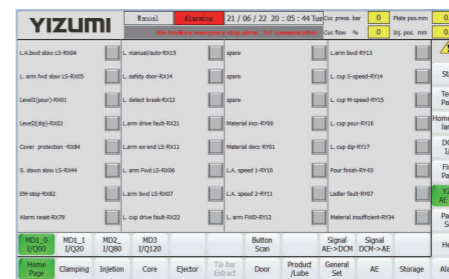

## Cell Integration

The HII-S control system features standardized interfaces offering great flexibility in the choice of peripherals. Cell integration made easy.

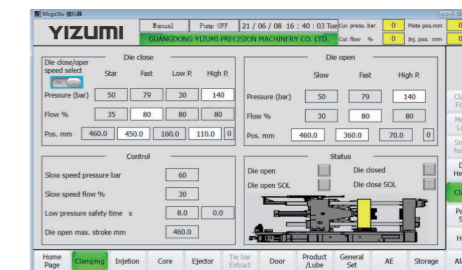

## Optimized HMI

Further optimized layout and structure of our HMI increases flexibility in managing machine functions via a large touchscreen. Intuitive and easy-to-understand maintenance functions such as maintenance tips, comprehensive alarm messages as well as operation guidance increase operational efficiency. Newly improved functions further include easy 1st phase pre-filling, mold pre-heating and plunger friction detection.

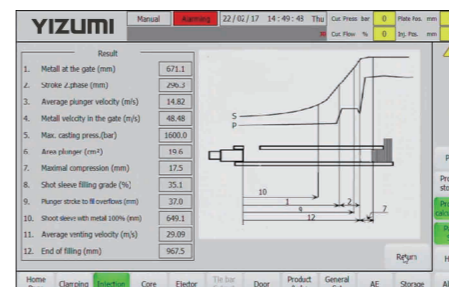

## Yi-CastMaster

The newly developed YIZUMI Castmaster is a great assistant for the production manager and process engineer and consists of following modules:

1. P/Q<sup>2</sup> diagram will support if the Max. machine capability match with the die requirement.
2. Automatic Casting parameter calculation helps to get the right shot profile.
3. Shot profile off-line browser function makes casting process analysis convenient.
4. Die/process management allows copy/paste the recipe between different machines.

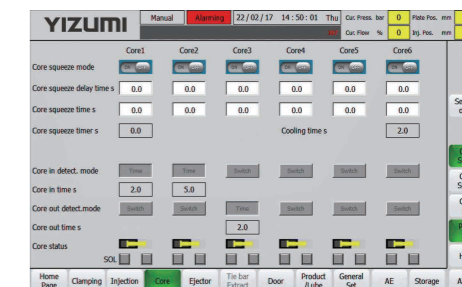

## Squeezing function with core puller

Every core pull may be used/programmed as an external squeeze pin. Convenient and flexible programming allows precise application of squeeze pin movements in order to eliminate possible shrinkage porosity in thick walled areas.

\* Data above are reference criterions for factory tests.

\* Data above are reference criterions for factory tests.



## YIZUMI Condition Monitor System (Optional)

The Yi-CMS platform is a perfect addition to YIZUMI's modern die casting machines & cells. Our Yi-CMS provides all functions and connectivity needed to fully integrate YIZUMI cells as well as other machinery in an Industry 4.0 plant manufacturing system.

### Machine Monitor

- The running status is viewed in real time
- Dynamic calculation of operational metrics
- Alarm information is collected in real time
- Timely warning of abnormal downtime

### Process Monitor

- Process parameters are collected in real time
- Timely warning of parameter anomalies
- Historical processing parameters are traced
- Process parameters SPC control

### Production Statistics

- Production progress monitoring
- Quality statistical analysis
- Hourly production statistics
- KPI exception alert



## Die Casting Cell Solution

### Efficient Cell Integration based on standardized Interfaces

YIZUMI's smart cell integration concept allows great flexibility in the choice of peripheral units. Engineering services include die casting machine, peripherals, after casting processes, color coded energy lines as well as complete safety concept's all in a professional solution with short delivery time.

- Standardized interfaces allow the configuration of efficient die casting cells.
- With a large variety of peripheral units according to customer preferences.
- Solutions include fully integrated ladle, spray and extractor or the use of any brand of peripheral.
- The YIZUMI Technical Services Team will work out the best solution for every customer.

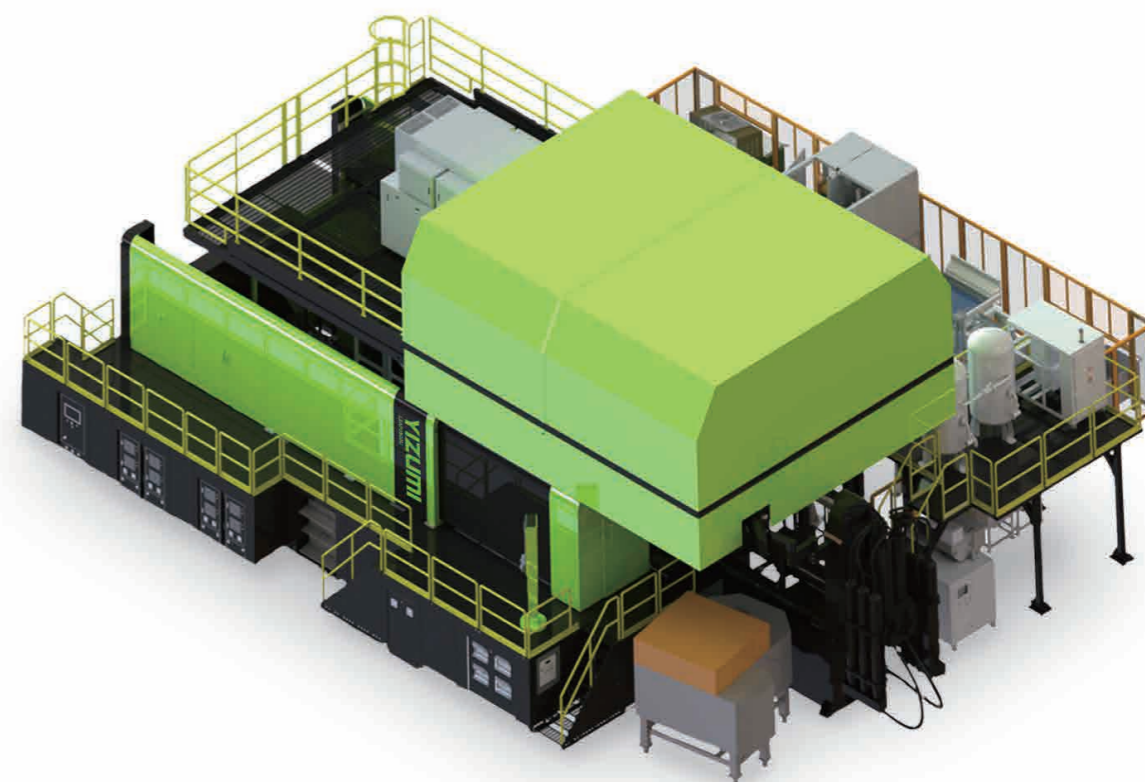

## Research Center for Die Casting and Metal Molding

### Yizumi Research Center for Die Casting and Metal Molding

Yizumi Gaoli plant has established Research Center for Die Casting and Metal Molding featuring a well equipped 3500T machine. The cell is equipped with an aluminum alloy dosing furnace incl. melt treatment with porous plugs, a high vacuum unit, a full set of mold thermoregulator unit (jet cooling, die temperature controller e.g.) and a whole set of robot automation unit. This infrastructure allows Yizumi Research Center for Die Casting and Metal Molding to meet the production demands of various large castings as well as structural castings.

Yizumi has created a real customer production environment, and can explore together with customers the core requirements of the die-casting process. Our aim is to provide a better and more satisfying equipment experience. Yizumi is working towards becoming the most cost-effective solution provider in the die-casting field.

### Yizumi Research Center 3500T Die Casting Cell

- Sprayer
- Ladler
- Part removal robot
- Air-cooling device
- Water-cooling device
- Pneumatic deslag device
- Dosing furnace
- Servo sawing device
- Safety fence
- Conveyor
- Vacuum machine
- Mold temperature controller
- Release agent mixing and feeding device
- Cylinder liner feed device
- Robotic polishing and deburring device
- Melting and holding furnace



## Technical Data

| ITEMS                           | UNIT            | DM180HII-S     | DM300HII-S     | DM400HII-S     | DM500HII-S     | DM650HII-S     | DM800HII-S     | DM900HII-S     |
|---------------------------------|-----------------|----------------|----------------|----------------|----------------|----------------|----------------|----------------|
| <b>CLAMPING UNIT</b>            |                 |                |                |                |                |                |                |                |
| Locking Force                   | kN              | 1800           | 3000           | 4000           | 5000           | 6500           | 8000           | 9000           |
| Locking Stroke                  | mm              | 380            | 460            | 550            | 580            | 670            | 760            | 760            |
| Space Between Tie Bars          | mm              | 460×460        | 570×570        | 650×650        | 750×750        | 780×780        | 930×930        | 960×960        |
| Die Height (Min. - Max.)        | mm              | 200-600        | 250-700        | 300-750        | 350-850        | 350-900        | 400-950        | 400-950        |
| Ejector Force                   | kN              | 105            | 150            | 180            | 240            | 300            | 360            | 360            |
| Ejector Stroke                  | mm              | 90             | 110            | 130            | 140            | 150            | 180            | 180            |
| <b>INJECTION UNIT</b>           |                 |                |                |                |                |                |                |                |
| Injection Force                 | kN              | 280            | 330            | 410            | 480            | 600            | 700            | 775            |
| Injection Stroke                | mm              | 350            | 410            | 510            | 580            | 650            | 760            | 760            |
| Plunger Diameter                | mm              | 50,60          | 50,60,70       | 60,70,80       | 70,80,90       | 70,80,90       | 80,90,100      | 80,90,100      |
| Injection Weight (Mg)           | kg              | 0.9,1.3        | 1.0,1.5,2.0    | 1.9,2.6,3.4    | 2.9,3.8,4.9    | 3.3,4.4,5.5    | 5.1,6.4,7.9    | 5.1,6.4,7.9    |
| Injection Weight (Al)           | kg              | 1.2,1.8        | 1.5,2.1,2.9    | 2.7,3.6,4.8    | 4.1,5.4,6.9    | 4.6,6.1,7.7    | 7.1,9.0,11.1   | 7.1,9.0,11.1   |
| Casting Pressure ( intensifg. ) | MPa             | 142,99         | 168,116,85     | 145,106,81     | 124,95,75      | 155,119,94     | 139,110,89     | 154,121,98     |
| Casting Area                    | cm <sup>2</sup> | 125,180        | 178,255,349    | 275,375,490    | 400,523,662    | 415,544,688    | 574,725,897    | 583,738,910    |
| Max. Casting Area (40MPa)       | cm <sup>2</sup> | 450            | 750            | 1000           | 1250           | 1625           | 2000           | 2250           |
| Injection Position              | mm              | 0,-140         | 0,-125         | 0,-175         | 0,-220         | 0,-250         | 0,-250         | 0,-250         |
| Plunger Penetration             | mm              | 130            | 155            | 210            | 250            | 280            | 300            | 300            |
| Casting Flange Diameter         | mm              | 110            | 120            | 130            | 150            | 165            | 200            | 200            |
| Casting Flange Protrusion       | mm              | 10             | 15             | 15             | 15             | 15             | 20             | 20             |
| <b>OTHER</b>                    |                 |                |                |                |                |                |                |                |
| Motor Capacity                  | kW              | 15             | 22             | 30             | 37             | 37             | 45             | 45             |
| Motor Capacity (SM)             | kW              | 30.4           | 43.6           | 43.6           | 55.5           | 48.1           | 75.7           | 75.7           |
| System Working Pressure         | MPa             | 16             | 16             | 16             | 16             | 16             | 16             | 16             |
| Oil Tank Capacity               | L               | 450            | 600            | 800            | 1000           | 1000           | 1200           | 1350           |
| Machine Dimension (LxWxH)       | mm              | 6200×1900×2600 | 6300×1990×2650 | 7450×2090×2750 | 7950×2280×2900 | 8400×2300×2910 | 9270×2420×3000 | 9700×2480×3050 |

\* Data above are reference criterions for factory tests.

Remark : We reserve the right to make any product improvement or specifications change without prior notice.  
Any product photos shown in catalogue are for future reference only.

# Standard and Optional Features

| ITEMS                                    | DM180HII-S | DM300HII-S | DM400HII-S | DM500HII-S | DM650HII-S | DM800HII-S | DM900HII-S |
|--|------------|------------|------------|------------|------------|------------|------------|
| <b>General</b>                           |            |            |            |            |            |            |            |
| Machine standard color*                  | ●          | ●          | ●          | ●          | ●          | ●          | ●          |
| Machine customized color                 | ○          | ○          | ○          | ○          | ○          | ○          | ○          |
| Manual safety door - left                | ●          | ●          | ●          | ●          | ●          | ●          | ●          |
| Manual safety door - right               | ●          | ●          | ●          | ●          | ●          | ●          | ●          |
| Electrical safety door - left            | ○          | ○          | ○          | ○          | ○          | ○          | ○          |
| Electrical safety door - right           | ○          | ○          | ○          | ○          | ○          | ○          | ○          |
| Toggle cover (left + right + top)        | ●          | ●          | ●          | ●          | ●          | ●          | ●          |
| Injection cove                           | ●          | ●          | ●          | ●          | ●          | ●          | ●          |
| <b>Electrical System</b>                 |            |            |            |            |            |            |            |
| PLC control system                       | ●          | ●          | ●          | ●          | ●          | ●          | ●          |
| 15" HD touch screen                      | ●          | ●          | ●          | ●          | ●          | ●          | ●          |
| Air conditioner                          | ○          | ○          | ○          | ○          | ○          | ○          | ○          |
| <b>Clamping System</b>                   |            |            |            |            |            |            |            |
| Stroke control - lineal transducer       | ●          | ●          | ●          | ●          | ●          | ●          | ●          |
| DDC system                               | ●          | ●          | ●          | ●          | ●          | ●          | ●          |
| Die height adjustment - manual           | ●          | ●          | ●          | ●          | ●          | ●          | ●          |
| Die height adjustment - position         | ●          | ●          | ●          | ●          | ●          | ●          | ●          |
| Die height adjustment-position and force | ○          | ○          | ○          | ○          | ○          | ○          | ○          |
| Locking force display                    | ●          | ●          | ●          | ●          | ●          | ●          | ●          |
| Hydraulic tie bar extraction             | —          | —          | ○          | ○          | ○          | ○          | ○          |
| <b>Hydraulic System</b>                  |            |            |            |            |            |            |            |
| Standard motor system                    | ●          | ●          | ●          | ●          | ●          | ●          | ●          |
| Servo motor system                       | ○          | ○          | ○          | ○          | ○          | ○          | ○          |
| <b>Core and Ejector</b>                  |            |            |            |            |            |            |            |
| Movable core- 1 set                      | ●          | ●          | —          | —          | —          | —          | —          |
| Movable core- 2 sets                     | ○          | ○          | ●          | ●          | ●          | ●          | ●          |
| Fix core- 1 set                          | ○          | ○          | —          | —          | —          | —          | —          |
| Fix core- 2 sets                         | ○          | ○          | ●          | ●          | ●          | ●          | ●          |
| Squeezing function core core-pulling     | ●          | ●          | ●          | ●          | ●          | ●          | ●          |
| Ejection stroke control - limit switch   | ○          | ○          | ○          | ○          | ○          | ○          | ○          |
| Ejection stroke control - magnetic tape  | ●          | ●          | ●          | ●          | ●          | ●          | ●          |
| <b>Injection System</b>                  |            |            |            |            |            |            |            |
| Stroke control - magnetic tape           | ●          | ●          | ●          | ●          | ●          | ●          | ●          |
| Flexible shot height positions           | ○          | ○          | ○          | ○          | ○          | ○          | ○          |
| Injection semi-close loop control        | ●          | ●          | ●          | ●          | ●          | ●          | ●          |
| Intelligent PPS curve technology         | ●          | ●          | ●          | ●          | ●          | ●          | ●          |
| RTCL control - speed                     | ○          | ○          | ○          | ○          | ○          | ○          | ○          |
| Acc. pressure release : auto             | ●          | ●          | ●          | ●          | ●          | ●          | ●          |
| Yi-CastMaster                            | ●          | ●          | ●          | ●          | ●          | ●          | ●          |
| <b>Others</b>                            |            |            |            |            |            |            |            |
| Oil temperature indicator                | ●          | ●          | ●          | ●          | ●          | ●          | ●          |
| Electrical oil temperature alarm         | ●          | ●          | ●          | ●          | ●          | ●          | ●          |
| Electrical oil level alarm               | ●          | ●          | ●          | ●          | ●          | ●          | ●          |
| Plunger lubricator                       | ○          | ○          | ○          | ○          | ○          | ○          | ○          |

\*RAL 7021, RAL 2010, RAL 9003, RAL 120 70 75

● Standard feature ○ Optional feature

# Platen Dimension Drawings

DM180HII-S

Where marked with , operator can put the ejector push / pull rod from the front or back of the ejector plate, Other holes only from the movable platen and to the rear platen. Mount the ejector push and pull rod symmetrically.

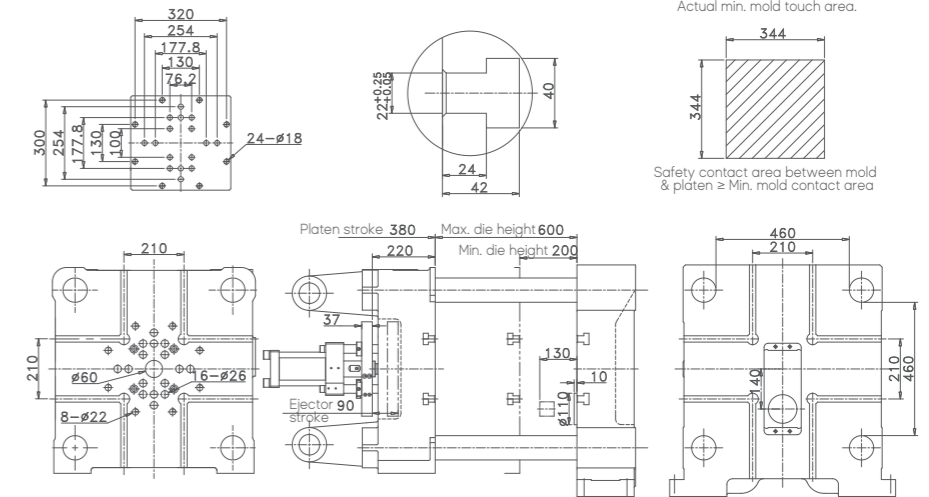

DM300HII-S

Where marked with , operator can put the ejector push / pull rod from the front or back of the ejector plate, Other holes only from the movable platen and to the rear platen. Mount the ejector push and pull rod symmetrically.

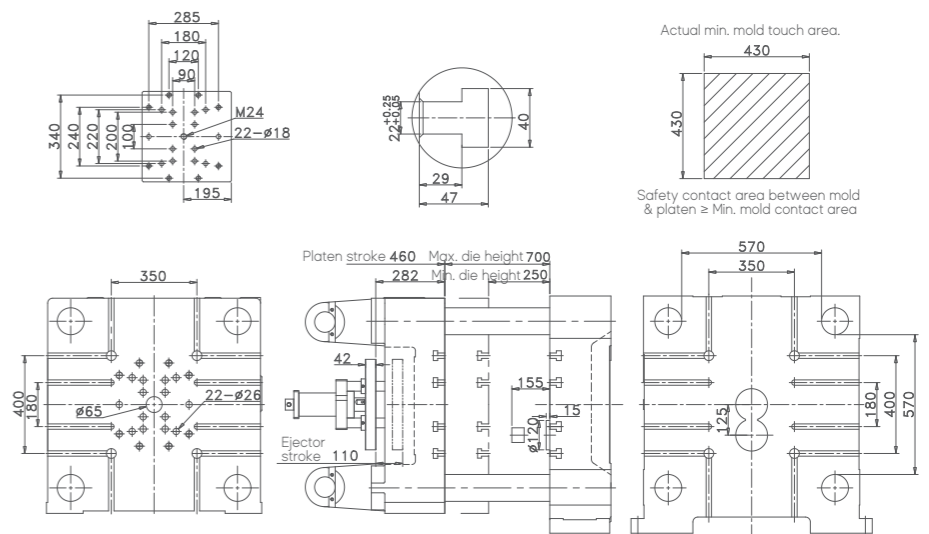

DM400HII-S

Where marked with , operator can put the ejector push / pull rod from the front or back of the ejector plate, Other holes only from the movable platen and to the rear platen. Mount the ejector push and pull rod symmetrically.

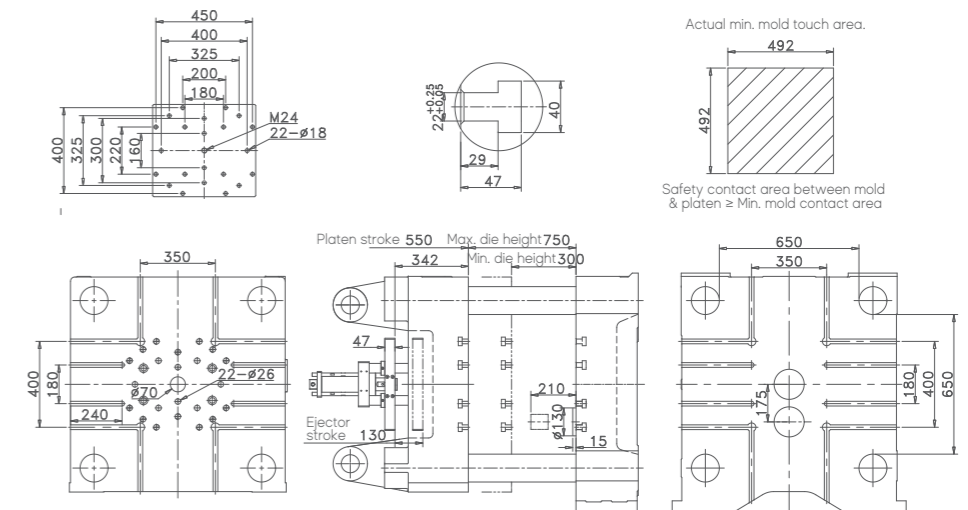

# Platen Dimension Drawings

## DM500HII-S

Where marked with , operator can put the ejector push / pull rod from the front or back of the ejector plate, Other holes only from the movable platen and to the rear platen. Mount the ejector push and pull rod symmetrically.

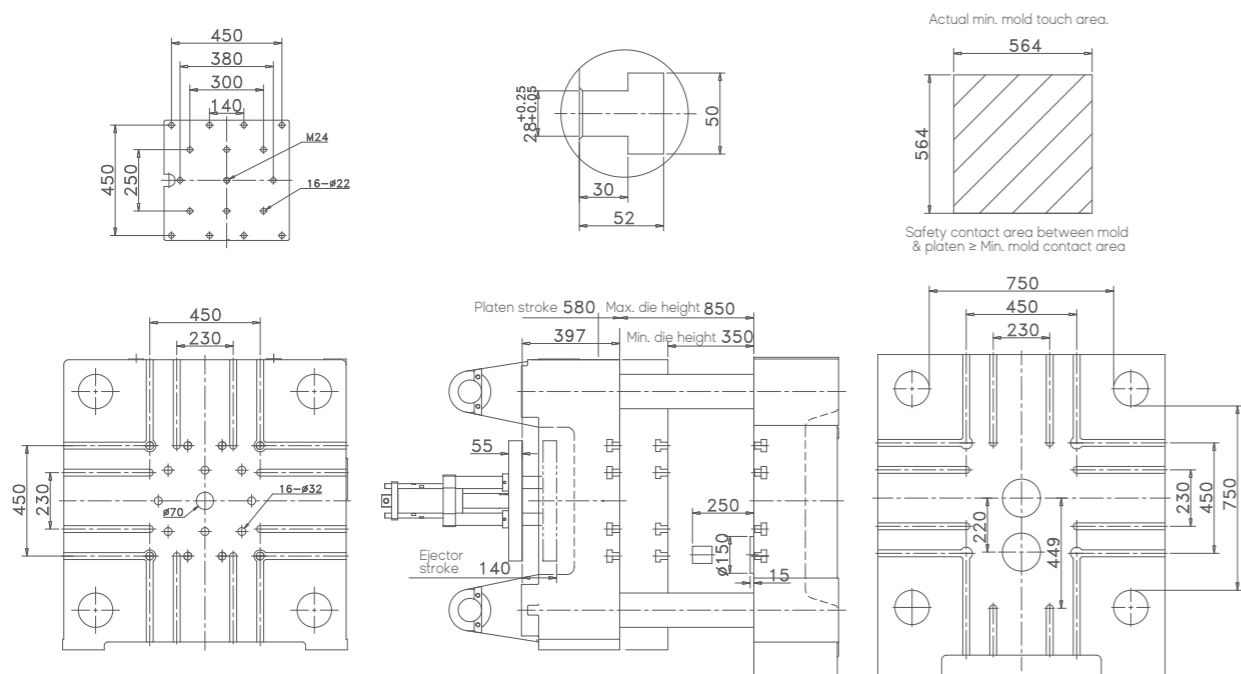

## DM800HII-S

Where marked with , operator can put the ejector push / pull rod from the front or back of the ejector plate, Other holes only from the movable platen and to the rear platen. Mount the ejector push and pull rod symmetrically.

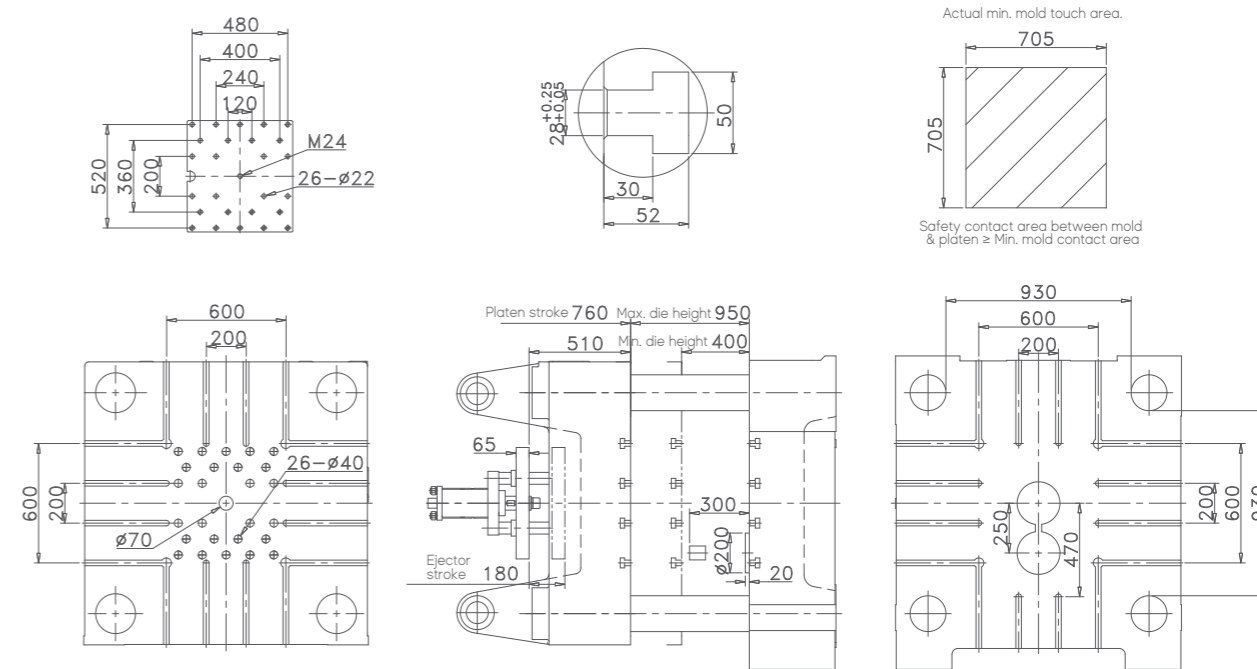

## DM650HII-S

Where marked with , operator can put the ejector push / pull rod from the front or back of the ejector plate, Other holes only from the movable platen and to the rear platen. Mount the ejector push and pull rod symmetrically.

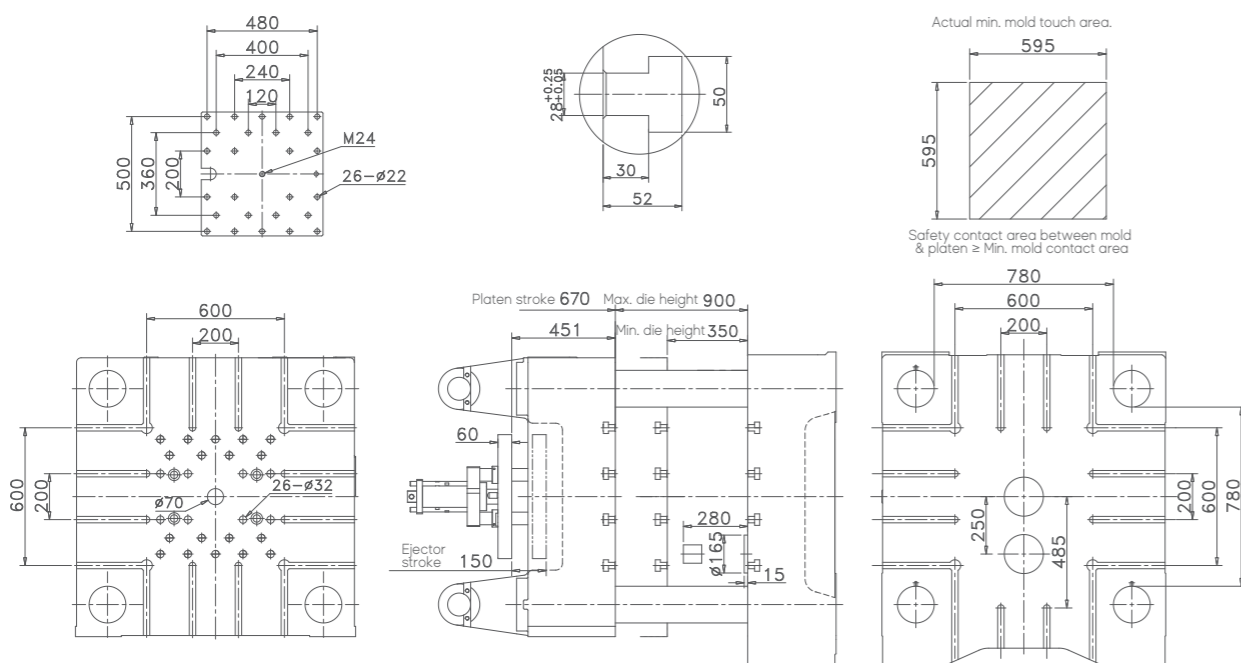

## DM900HII-S

Where marked with , operator can put the ejector push / pull rod from the front or back of the ejector plate, Other holes only from the movable platen and to the rear platen. Mount the ejector push and pull rod symmetrically.

