

THINK TECH FORWARD

Designed by Yizumi, April 2023

**YIZUMI**

**LEAP**

**380T-9000T**

LEAP SERIES DIE CASTING MACHINE

World class die casting

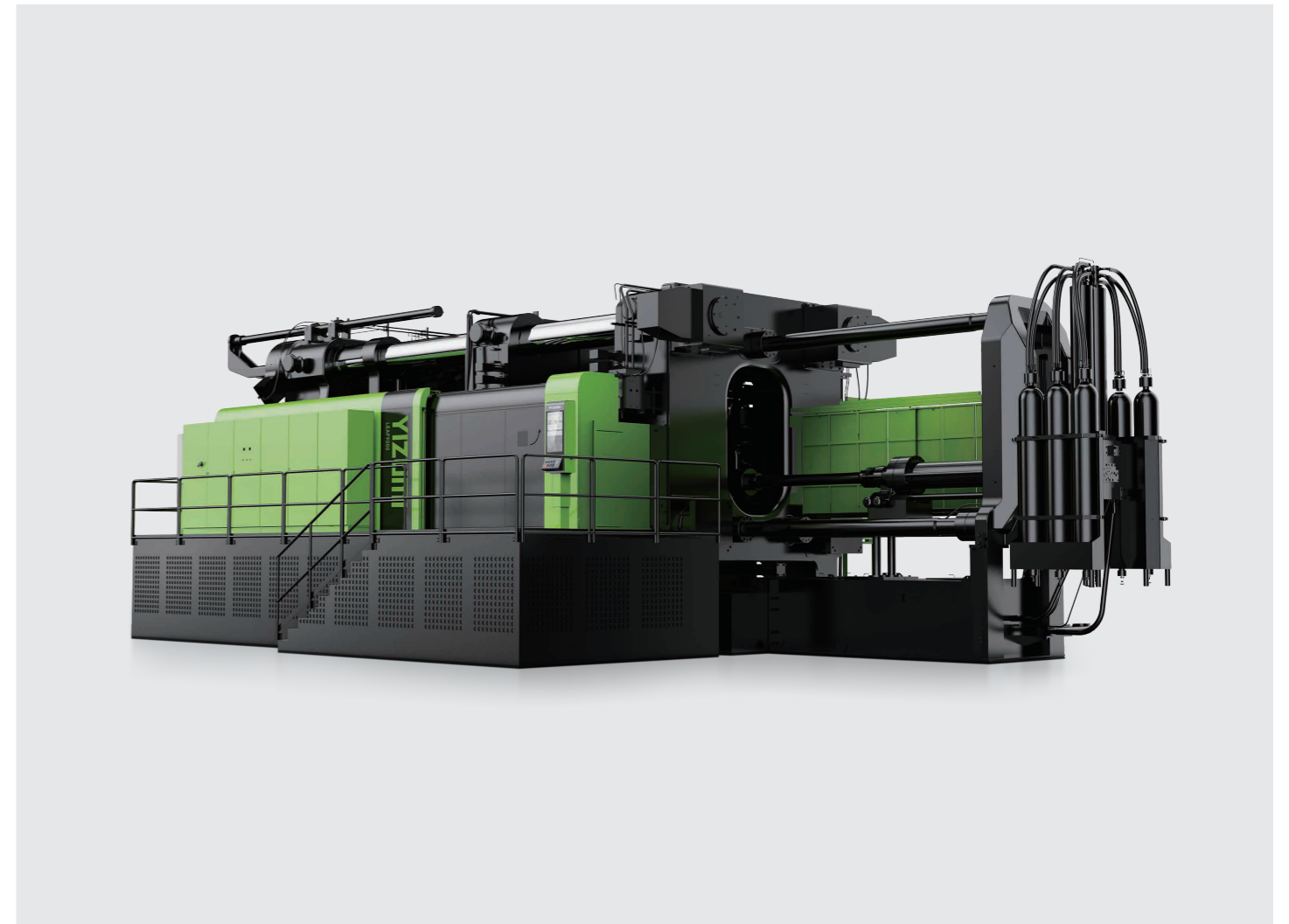

**Yizumi Holdings Co., Ltd.**

Address: No.22 Ke Yuan 3rd Road, Shunde, Foshan, Guangdong 528300, China  
TEL: 86-757-2926 5301 86-757-2926 5300(overseas) Email: dcsolutions@yizumi.com  
www.yizumi.com

**[DISCLAIMER]**

- [1] YIZUMI reserves the right to modify the product description in the catalogue. Specification might be changed without prior notice.
- [2] The picture in the catalogue is for reference only. The real object should be considered as final.
- [3] The data in the catalogue is obtained from internal testing in YIZUMI laboratory.  
Please refer to the actual machine for the final data. YIZUMI reserves the right of final interpretation upon disputes and ambiguities.



THINK TECH FORWARD

# LEAP

PRODUCT DETAILS

# PRODUCT DETAILS

YIZUMI LEAP is the result of connecting advanced international engineering expertise with YIZUMI's experienced R&D team. This state of the art technology provides our customers with highest casting precision and top of the line reproducibility. LEAP Technology, with its innovative hydraulic and high performing control system with intuitive HMI, ensures maximum casting process control to achieve highest production efficiency.

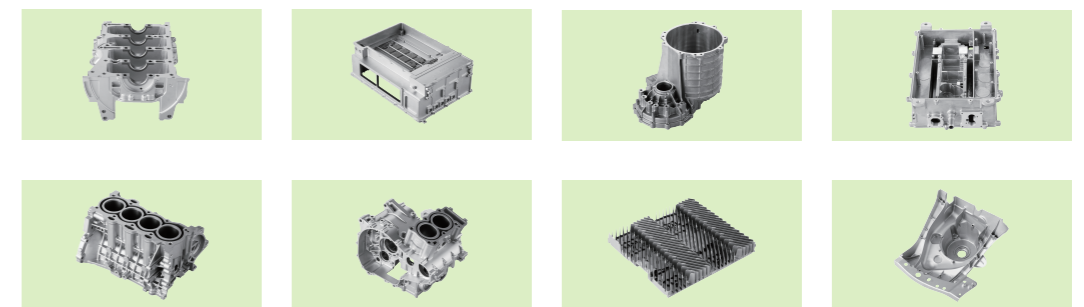

# WORLD CLASS DIE CASTING

LEAP SERIES  
DIE CASTING MACHINE



## User-Friendly

Intuitive ORCA-HMI  
by YIZUMI

## Highly Efficient

10 % faster &  
highly repeatable

## Precise & Repeatable

Yi-Cast  
Self-learning real-time control

## Energy-Saving

Up to 40 %  
with innovative hydraulic



# VISION 2025

BEST RETURN ON INVESTMENT  
FOR OUR CUSTOMERS

To be the industry's best cost-effective solution provider with leading technology

## Integrated Die Casting Solutions

At YIZUMI we understand the great importance of a fully integrated and efficient die casting cell. Therefore we designed the LEAP die casting machine in a way that our specialists can flexibly integrate a die casting manufacturing cell with customer's preferences in mind and ensure you receive a die casting solution from YIZUMI which provides you with the best OEE in your production.

## Competent Support

Our customers can rely on YIZUMI after sales support in every market world wide. We commit ourselves to providing a top class support to our customer in areas of technical support and spare parts availability.

Yizumi tops it off with quality training on technical equipment and casting process either at its HQ in China or on customer's site.

We also go the extra mile, supporting our customers to optimize their die-casting process onsite at their factories.

## State-of-the-art Die Casting Technology

We are committed to providing leading technology to our customers worldwide. Based on our 12086 die casting machines currently operating in the market, our collaboration with top class engineering experts from Europe has enabled us to create the LEAP die casting system - providing true State of the Art Technology to you.

## User-Friendly

Intuitive ORCA-HMI  
by YIZUMI

## Highly Efficient

10 % faster &  
highly repeatable

## Energy-Saving

Up to 40 % with  
innovative hydraulic

## Precise & Repeatable

Yi-Cast self-learning  
real-time control

LEAP

# THE ROAD TO LEAP

In recent years, in keeping with the general trend of energy conservation and emission reduction, the global demand for new energy vehicles has ushered in rapid growth. The die-casting industry is facing a new round of transformation and upgrading in which new energy vehicles put forward higher requirements for die-casting technology and complex thin-walled die-casting parts.

To address this challenge, from smart cell integration, die design and casting process optimization, we benchmark the key performance of the machine against the international advanced level. Through the improvement of equipment availability, process repeatability, and precision, customers will achieve higher OEE.

To bring competitive value to customers, YIZUMI decided that a holistic approach would be the key to this revolutionary leap.

“An innovation as significant as the LEAP die casting machine can not be done by single individuals. Rather, such innovations are a result of our collaboration with interdisciplinary experts and customers.”

— Stefan Fritsche

YIZUMI CSO for Die Casting & Metal Forming

## The Power of Connection

“Deep connection” is the driving force behind YIZUMI’s technological leadership. To create a new generation of revolutionary products, YIZUMI is committed to connecting advanced European die-casting technology with YIZUMI capabilities. The China-Europe technology-platform we built introduces European diecasting experts to overcome technical challenges together with our experienced R&D team. At the same time, we cultivate the core technical capabilities of our Chinese engineers, from knowledge transfer to active creation.



## The YIZUMI-customer Collaboration

At the beginning of product development, we actively applied our IPD (Integrated Product Development) method, with its market-orientation and focus on customer needs & requirements. We learned to understand the pain-points of customers’ employees in their diverse roles in actual production and use of die casting equipment. Through several years of in-depth observation and research, we obtained first-hand feedback, which helped LEAP products to achieve a leap in key performance.

To generate more possibilities for the product, we have also connected European partners with rich industry experience, merging internal and external die-casting expertise to create a technical team with international perspectives for the benefit of our customers.

“This time we established a fantastic product with great energy efficiency and top of the line injection performance and repeatability for the YIZUMI brand. I am really proud of our work and the whole team and of our international collaboration.”

— Daniel

Chief expert of injection system In YIZUMI LEAP Project



# CONNECTING WITH GLOBAL ADVANCED DIE CASTING TECHNOLOGY

An enhanced, high-strength three-platen die casting machine designed by an international engineering team with long-standing die casting machine design experience.

LEAP's advanced, real time closed loop injection provides highest international level of casting performance resulting in highest OEE.

The system is complemented by a highly innovative and energy saving hydraulic drive-group as well as a state-of-the-art HMI featuring highly intuitive programming. World Class Technology at fair prices.

## | Industry 4.0 Ready

Continuous improvement is based on accurate and timely feedback of a large variety of production and casting process data. With the LEAP die casting system, YIZUMI offers its customers an advanced platform able to smartly manage and improve machine utilization and process quality based on data management of all relevant parameters influencing the casting process.

## | Maintenance friendly – Safety First in Overall Design

Designed with safety in mind, control cabinets and machine enclosures allow best maintenance access for highly efficient operations.

## | YIZUMI MES Solution for Perfect Production Management.

With its in-house solutions Yi-CMS & Yi-MES, YIZUMI offers efficient management of key production & process data and thus enhances productivity of one or multiple casting cells.

## Energy Saving, Innovative Drive Group

Digital constant pump or high dynamic servo pump, YIZUMI offers energy efficient drive groups offering precise hydraulic movements, high protection of hydraulic components with a long service life and an energy consumption of **up to 40%** below conventional systems.

## Interfaces for Smart Cell Integration

Standardized signal or bus system interfaces allow flexible and easy cell integration with any peripheral standards used worldwide by customers.

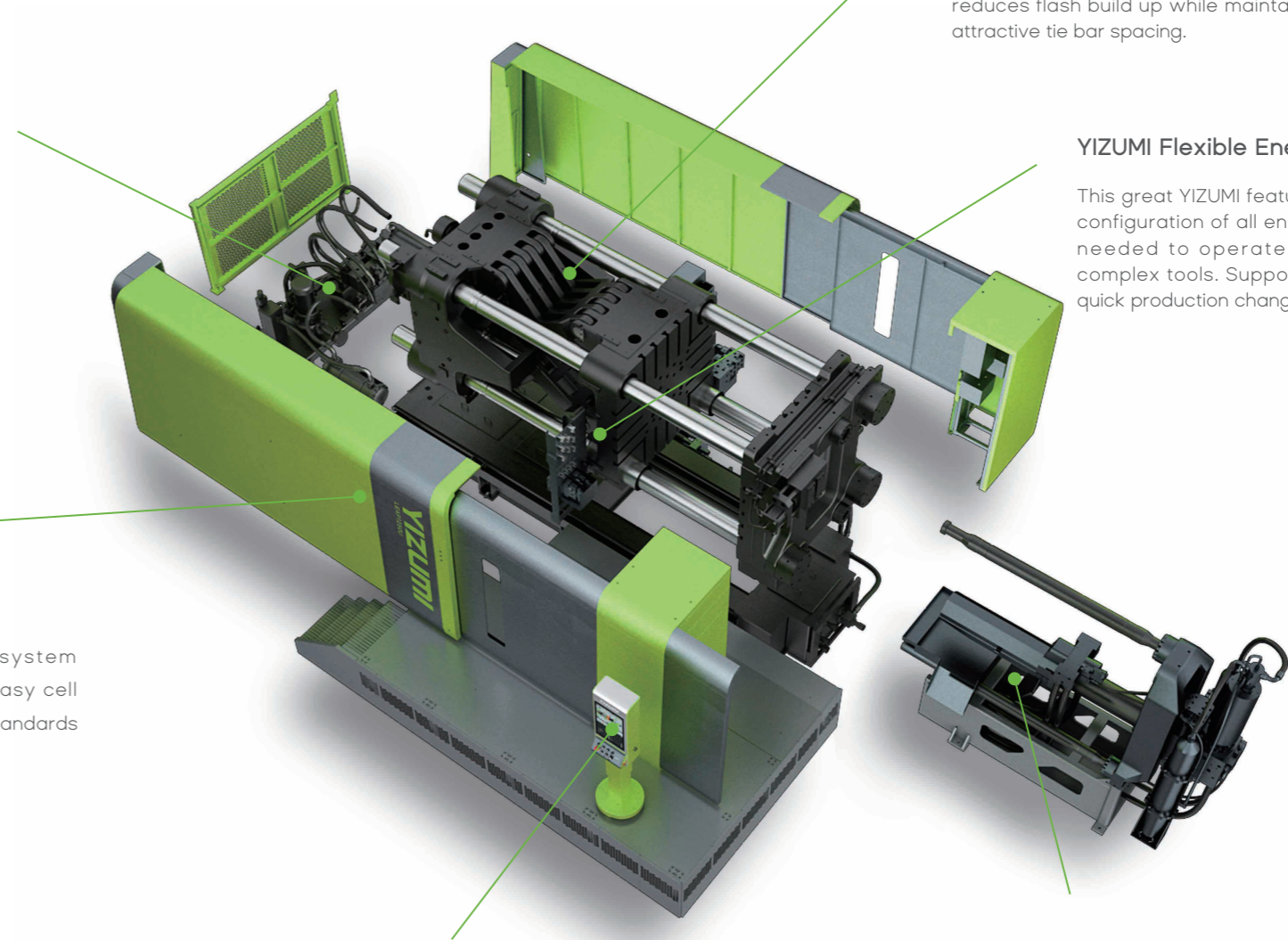

## Rigid and Fast-moving Clamping System

Re-designed for performance, our toggle system provides fast and accurate die movements. Increased stability of the platen reduces flash build up while maintaining an attractive tie bar spacing.

## YIZUMI Flexible Energy Board

This great YIZUMI feature allows flexible configuration of all energy connections needed to operate even the most complex tools. Supports also safe and quick production changes.

## YIZUMI ORCA-HMI with Full Performance Control

With its structured, intuitive graphic supported HMI menu, the YIZUMI ORCA control allows full management of critical production parameters with ease and efficiency. With minimum training needed, this control system reduces complexity for all its users.

## YIZUMI Yi-cast Injection Unit – Quality with Every Shot.

Making use of the most advanced technology for its real time closed loop shot control, YIZUMI LEAP provides its users with highest precision and repeatability for every shot.

# SMART CONTROL SYSTEM

## YIZUMI ORCA Control System

- Yizumi Die Casting Machine Smart Control System is the result of close cooperation between Yizumi and European experts. It provides customers with an advanced digital platform that can be managed based on data of all relevant die casting process parameters to improve efficiency of machine use and process quality.
- The ORCA control system features an industrial computer IPC and a large HD multi-touch screen HMI with intuitive interactive graphic program menus. Support and guiding functions such as comprehensive alarm messages, multi-function injection curve display as well as preventive maintenance references and casting technology information ensure highest operational efficiency.
- In line with the future development, the intelligent control system comes with AI attributes. Functionality simulating mobile phone operation allows for ease of use to manage process parameters and system programming with highest efficiency and a minimum of training.
- Comprehensive Statistical Process Control (SPC) functions ensure transparent quality management of any casting production with a focus to achieve highest Overall Equipment Efficiency (OEE)

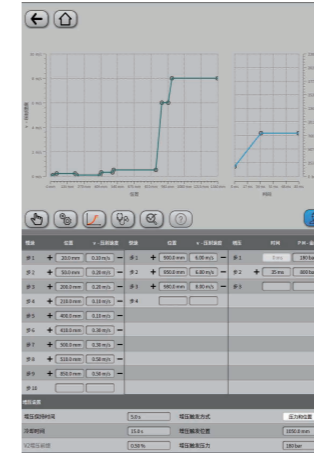
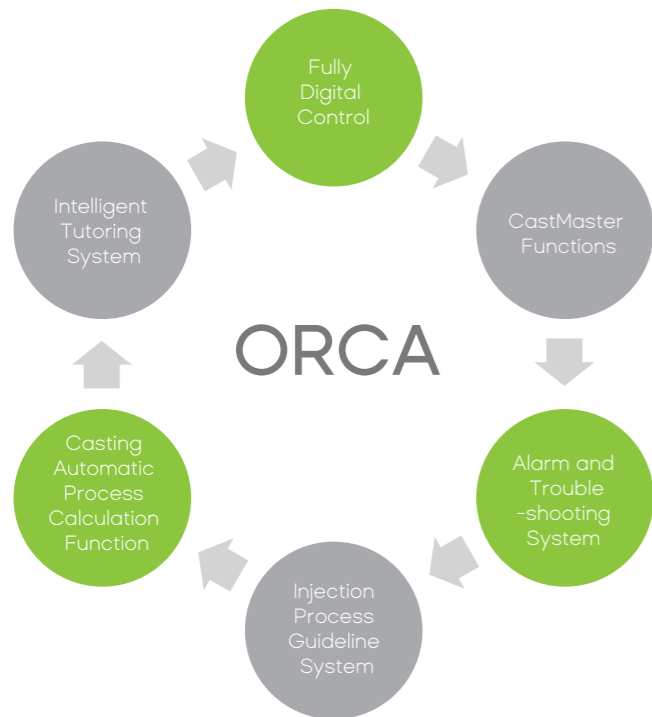

### Fully Digital Control

With its easy-to-understand and intuitive graphical HMI, the ORCA control system provides maximum flexibility in managing the casting process.

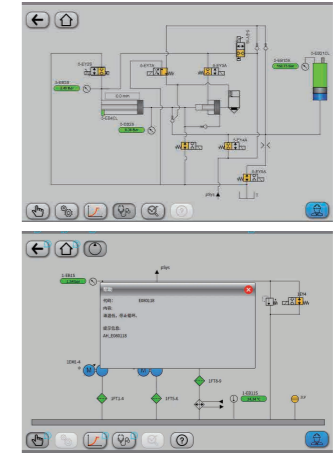

### Alarm and Trouble-shooting System

The ORCA control system has a well-documented alarm system built in to provide operational guidance and rapid troubleshooting to customers.

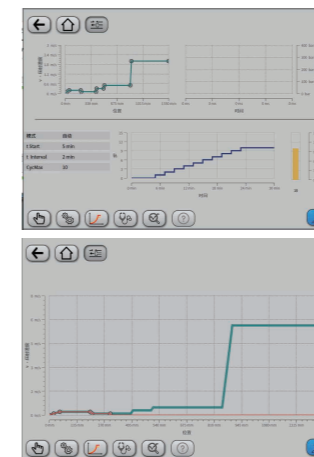

### Professional application tool

The ORCA control system features various professional and smart application tools allowing users to program and manage the casting process with ease and highest transparency.

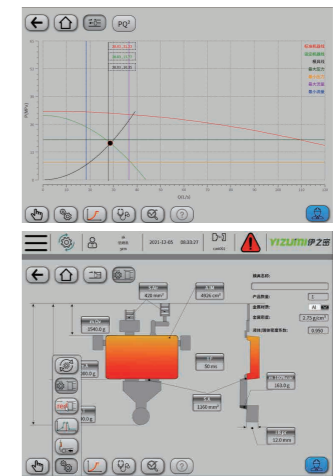

### CastMaster Functions

The ORCA control system features a "built-in experts' system" which can guide customers with valuable technology information in the diecasting process.



## KEY FEATURES



### YIZUMI LEAP Injection Unit –Quality with Every Shot.

This is innovation by YIZUMI. A powerful combination of state-of-the-art casting injection control performance at fair prices. Developed by YIZUMI with an international team of highly experienced engineers, our LEAP system offers highest casting performance. Finely adjusted algorithms which have been developed in-house combined with a high-performance control system, high speed pilot valves and special purpose servo valves offer you a world class injection performance.

The YIZUMI real time closed loop control system detects any process deviation and immediately adjusts the injection process. **This greatly enhances your process repeatability and your casting quality consistency. Breaking of the injection speed at the end of cavity filling reduces flash and increases productivity and die life.**

### YIZUMI ORCA Control System & Performance HMI

A top of the line control system designed by YIZUMI.

The result of a close collaboration between YIZUMI and renowned European specialists, the YIZUMI ORCA enhances casting process management in every aspect. Intuitive and easy to understand graphical screens save programming time and reduce extensive training needs. The HMI menu conveniently offers easy access for operators, process engineers, maintenance teams as well as quality managers alike.

The user interface with its large touch screen provides direct access to programming functions, alarm messages as well as the multifunctional shot curve display.

Tolerance bands set for critical process parameters and SPC data management make quality management easy to ensure highest OEE for you.

### Enhanced YIZUMI Locking End

Energy consumption  
up to  
**40%**  
reduction

**10%**  
faster  
closing & opening times

A new fully re-engineered toggle system for extended service life and higher platen rigidity.

10% faster closing and opening times are achieved in combination with the innovative YIZUMI hydraulic drive system. The proven servo motors, a technology which has been in use for years at YIZUMI, reduce up to 40% energy consumption.

Easy programming of speeds, automatic die-height & locking force as well as precise die-position-stops add to the overall efficiency.

Flexible energy boards allow easy adjustments and customization of all energy & functional connections between the DCM and the die casting tool.

### Performance Focused Machine Design

The result of a close cooperation between the YIZUMI design team and a professional design outfit provides our customers with a new YIZUMI die casting machine design focused on efficient & safe operation in your die casting plants.

Safety first and foremost. Our new design protects your personnel by keeping energy lines and moving parts away, while allowing open access to your operations and maintenance teams in a perfect balance between safety and efficiency.



# PERIPHERAL DEVICES

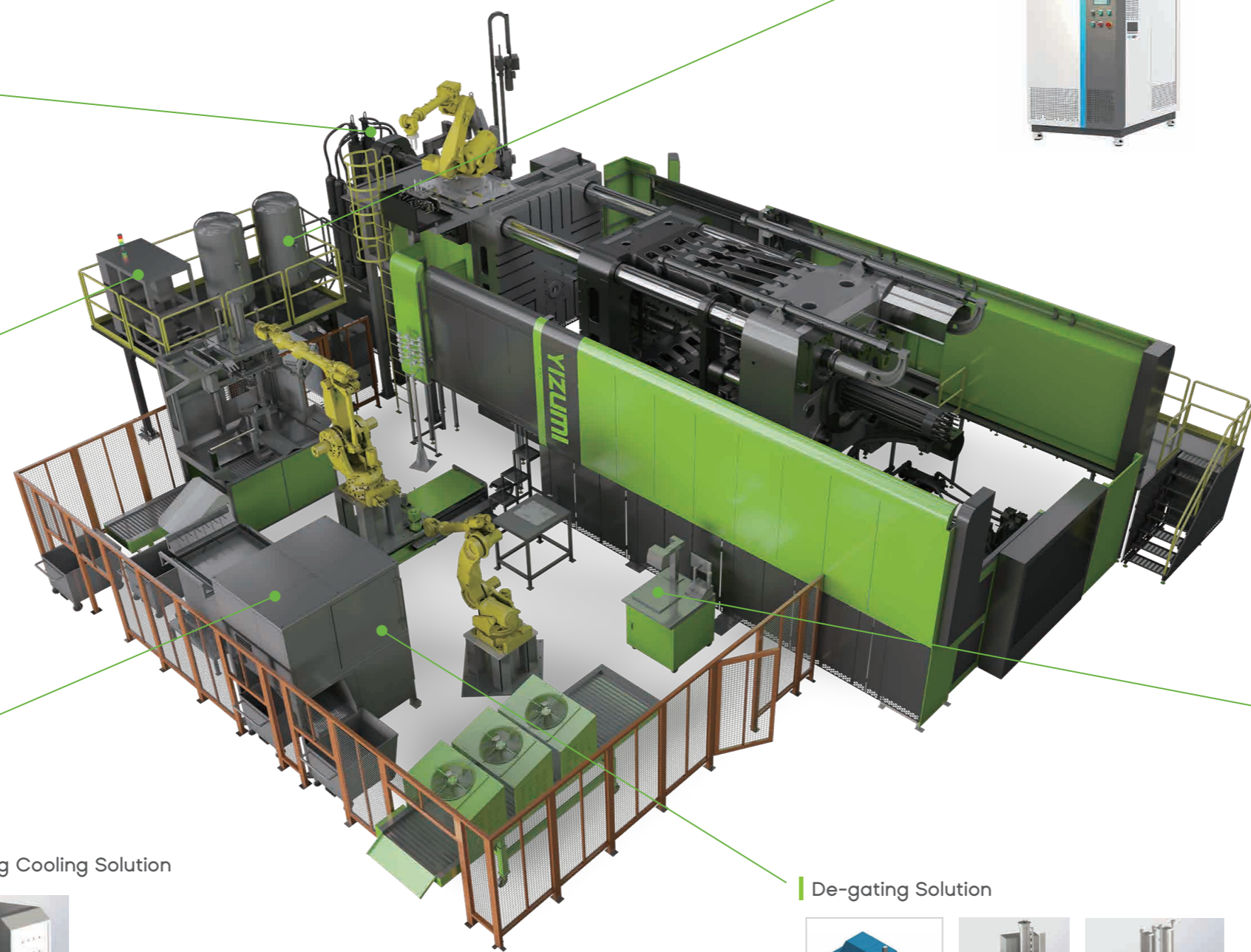

## Die Spraying Solution

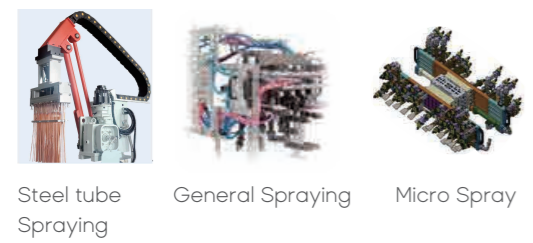

Steel tube Spraying    General Spraying    Micro Spray

## Mold Constant Temp. Solution



Die Temperature Controller    Jet Cooling

## Overflow Removal Solution



Customized Contour Hammer    Pneumatic knockoff hammer

## Casting Cooling Solution



## Vacuum System



## Exhaust Hood Solution



## Product Deburring Solution

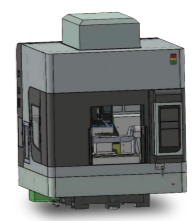

## Product Traceability Solution Encoder/Code Marking

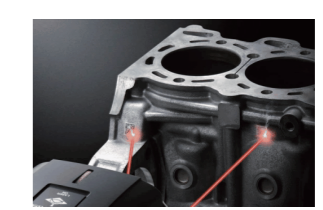

## De-gating Solution



Sawing machine    Trimming press    Breaker



# RESEARCH CENTER FOR DIE CASTING AND METAL MOLDING

## Yizumi Research Center for Die Casting and Metal Molding

Yizumi Gaoli plant has established Research Center for Die Casting and Metal Molding featuring a well equipped 3500T machine. The cell is equipped with an aluminum alloy dosing furnace incl. melt treatment with porous plugs, a high vacuum unit, a full set of mold thermoregulator unit (jet cooling, die temperature controller e.g.) and a whole set of robot automation unit. This infrastructure allows Yizumi Research Center for Die Casting and Metal Molding to meet the production demands of various large castings as well as structural castings.

Yizumi has created a real customer production environment, and can explore together with customers the core requirements of the die-casting process. Our aim is to provide a better and more satisfying equipment experience. Yizumi is working towards becoming the most cost-effective solution provider in the die-casting field.



### Mold Flow and Process Analysis

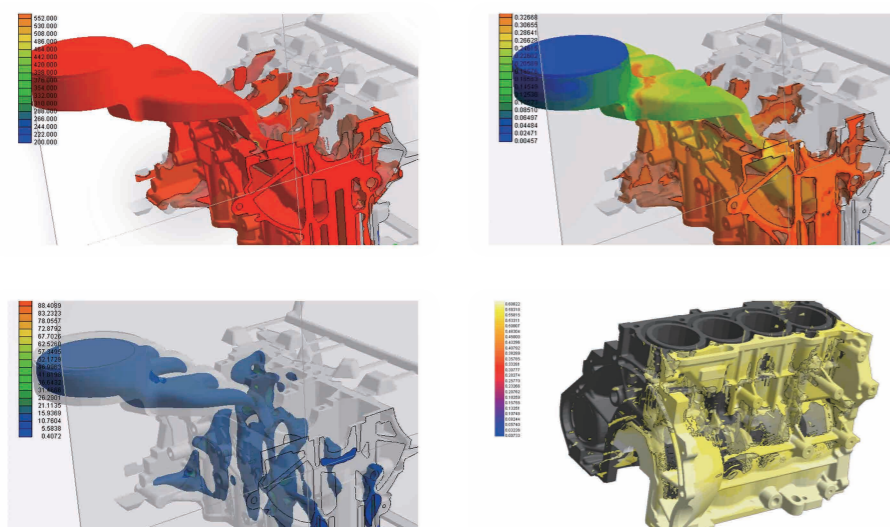

YIZUMI teams are familiar with die casting processes and have built up professional knowledge in structural parts.

Our die-casting solutions provide customers with customized die design support and on-site process optimization. From general castings to thick walled, pressure tight parts, medium wall thickness parts with mechanical stress requirements, and thin wall parts with high surface requirements, etc., we can guarantee stable and consistent quality and realize traceability of the whole production.

### YIZUMI Production Examples



# TECHNICAL DATA

ITEM	Die Locking Force	Die Stroke	Die Height (Min.-Max.)	Tie-Bar Space (HXV)	Ejector Force	Ejector Stroke	Shot Force	Dynamic Shot Force	Shot Stroke	Plunger Diameter	Injection Weight (Al)	Casting Pressure (Intensification)	Casting Area	Casting Area Max.(40MPa)	Shot Position	Plunger Following Stroke	Shot Sleeve Flange Diameter	Shot Sleeve Flange Protrusion	Working Pressure	Motor Capacity (SM)	Hydraulic Oil Tank Capacity
	kN	mm	mm	mm	kN	mm	kN	kN	mm	mm	kg	MPa	cm <sup>2</sup>	cm <sup>2</sup>	mm	mm	mm	mm	MPa	kW	L
LEAP840	8000	760	400-950	930×930	360	180	770	290	760	80-100	7.1-11.0	153-98	549-857	2100	0/-250	300	200	20	21	66.3	1200
LEAP920	9000	760	400-950	960×960	360	180	770	280	760	80-100	7.1-11.0	153-98	601-939	2300	0/-250	300	200	20	21	66.3	1200
LEAP1050	10500	880	450-1100	1030×1030	500	200	1100	410	850	90-120	10-17.7	172-97	610-1082	2625	0/-300	300	240	20	21	76.4	2200
LEAP1250	12500	1000	450-1200	1100×1100	550	200	1100	410	850	100-140	12.3-24.2	140-71	892-1760	3125	0/-320	290	240	25	21	76.4	2200
LEAP1400	14000	1000	450-1200	1100×1100	550	200	1100	410	850	100-140	12.3-24.2	140-71	1000-1971	3500	0/-320	290	240	25	21	76.4	2200
LEAP1650	16500	1200	500-1400	1250×1250	600	250	1530	590	1050	110-150	18.4-34.3	161-86	1024-1918	4125	0/-400	400	260	25	21	88.4	2800
LEAP1850	18500	1200	500-1400	1250×1250	600	250	1530	590	1050	110-150	18.4-34.3	161-86	1149-2151	4625	0/-400	400	260	25	21	88.4	2800
LEAP2000	20000	1400	600-1600	1350×1350	650	300	1530	590	1050	120-160	22-39	135-76	1481-2631	5000	0/-400	450	260	30	21	88.4	2800
LEAP2200	22000	1400	600-1600	1350×1350	650	300	1530	590	1050	120-160	22-39	135-76	1629-2894	5500	0/-400	450	260	30	21	88.4	2800
LEAP2500	25000	1500	700-1800	1500×1500	750	300	2300	820	1400	140-180	39.8-65.8	149-90	1677-2777	6250	0/-450	500	280	30	21	152.8	4000
LEAP2800	28000	1500	700-1800	1500×1500	750	300	2300	820	1400	140-180	39.8-65.8	149-90	1879-3111	7000	0/-450	500	280	30	21	152.8	4000
LEAP3000	30000	1500	800-2000	1650×1650	900	300	2300	820	1400	140-180	39.8-65.8	149-90	2013-3333	7500	0/-450	500	280	30	21	152.8	4000
LEAP3200	32000	1500	800-2000	1650×1650	900	300	2300	820	1400	140-180	39.8-65.8	149-90	2147-3555	8000	-300/-600	500	280	30	21	152.8	4000
LEAP3500	35000	1600	850-2000	1750×1750	900	300	2300	820	1400	160-200	52-81.2	114-73	3070-4794	8750	-300/-600	600	320	35	21	152.8	4000
LEAP4000	40000	1800	900-2100	1850×1850	1100	400	2800	1165	1600	160-200	59.4-92.8	139-89	2877-4494	10000	-300/-600	700	320	35	21	176.8	4800
LEAP4500	45000	1900	1100-2200	1950×1950	1100	400	2800	1165	1600	180-220	75.2-112.3	110-73	4090-6164	11250	-300/-600	700	340	35	21	176.8	4800
LEAP5000	50000	1900	1100-2200	1950×1950	1100	400	2800	1165	1600	180-220	75.2-112.3	110-73	4545-6849	12500	-300/-600	700	340	35	21	176.8	4800

Remark: Please contact us if you want to know more about other machine models.



# DIMENSION PARAMETER

ITEM	LPA01	LPA02	LPB	LPC01	LPC02	LPD01	LPD02	LPD03	LPE	LPE01	LPE02	LPF	LPF01	LPF02	LPF03	LPG	LPG01
LEAP840	5580-6130	3830	400-950	1270-1520	3030-3300	2600	1610	2220	8900	1240	4440	2660	1350	1330	1120	1220	610
LEAP920	5680-6230	3930	400-950	1325-1575	3050-3300	2680	1660	2220	9000	1240	4520	2730	1370	1370	1160	1220	610
LEAP1050	6640-7290	4980	450-1100	1340-1640	3000-3400	3080	1720	3060	10800	1950	5490	4720	2720	2000	1660	1400	790
LEAP1250	7100-7850	5350	450-1200	1490-1810	3220-3600	3180	1890	3160	11200	1990	5790	4720	2720	2000	1660	1410	800
LEAP1400	7100-7850	5350	450-1200	1490-1810	3220-3600	3180	1890	3160	11200	1990	5790	4720	2720	2000	1660	1410	800
LEAP1650	8350-9250	6110	500-1400	1500-1870	3650-4100	3440	1945	3170	12700	2000	6400	5180	2950	2230	1890	1680	890
LEAP1850	8350-9250	6110	500-1400	1500-1870	3650-4100	3440	1945	3170	12700	2000	6400	5180	2950	2230	1890	1680	890
LEAP2000	9280-10300	6750	600-1600	1565-1965	3750-4200	3580	2020	3170	13500	2000	6960	5630	3150	2480	2140	1680	890
LEAP2200	9280-10300	6750	600-1600	1565-1965	3750-4200	3580	2020	3170	13500	2000	6960	5630	3150	2480	2140	1680	890
LEAP2500	11000-12100	8250	700-1800	1800-2250	3950-4400	4100	2330	3400	15900	2420	8200	6130	3400	2730	2390	1850	980
LEAP2800	11000-12100	8250	700-1800	1800-2250	3950-4400	4100	2330	3400	15900	2420	8200	6130	3400	2730	2390	1850	980
LEAP3000	11300-12500	8450	800-2000	1960-2410	4120-4600	4380	2490	3400	15900	2420	8200	6130	3450	2730	2390	1850	980
LEAP3200	11300-12500	8450	800-2000	1960-2410	4120-4600	4380	2490	3400	15900	2420	8200	6130	3450	2730	2390	1850	980
LEAP3500	11300-12450	8550	850-2000	2130-2730	4280-4900	4480	2800	3910	16000	2670	7960	6180	3450	2730	2390	1850	980
LEAP4000	12500-13700	9250	900-2100	2145-2745	5050-5700	4910	2820	3910	17200	2290	8710	6650	3660	2990	2650	2180	1020
LEAP4500	13110-14210	9620	1100-2200	2210-2810	5120-5800	5080	2890	3910	17800	2290	9180	6650	3660	2990	2650	2180	1140
LEAP5000	13110-14210	9620	1100-2200	2210-2810	5120-5800	5080	2890	3910	17800	2290	9180	6650	3660	2990	2650	2180	1140

Remark: Please contact us if you want to know more about other machine models.

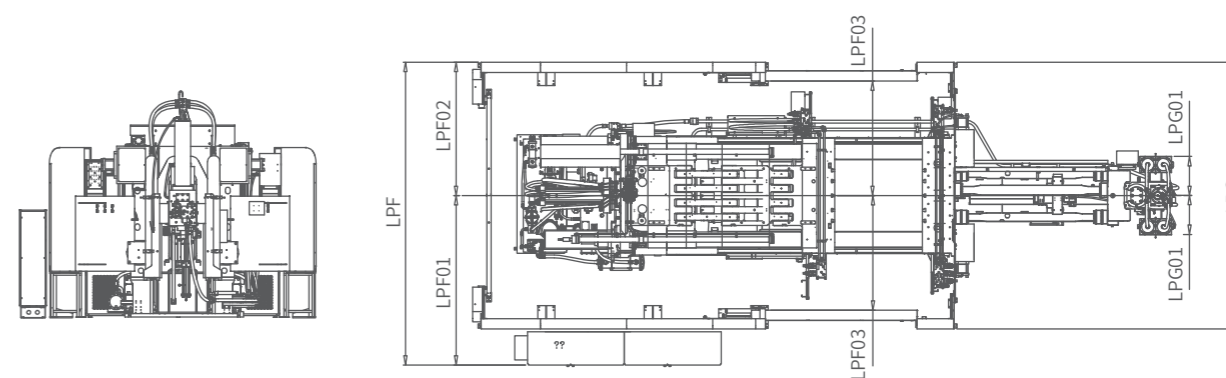
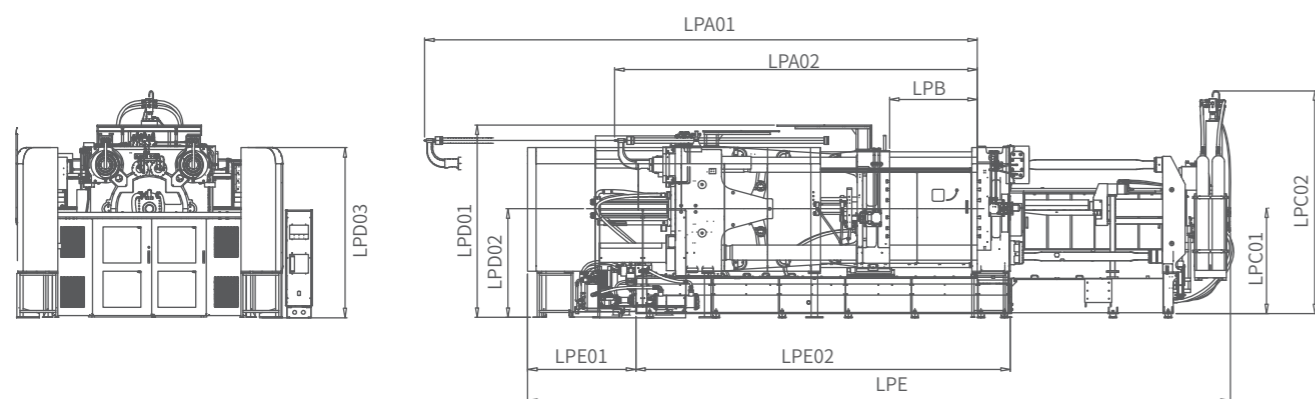

\* The data are obtained from Yizumi's laboratory test, and the final interpretation right belongs to Yizumi.

# YIZUMI CUSTOMER SERVICE

## Professional & Fast

The YIZUMI YFO Customer Service in China ensures high-quality customer service 24/7. In 39 international markets, YIZUMI provides fast and competent customer services by means of trusted and trained agencies and representatives. In Germany, the USA and India YIZUMI Die Casting operates wholly owned subsidiaries providing high level technical as well as pre- and post-sales services.

## YIZUMI at Your Service

Worldwide, YIZUMI has successfully implemented > 8000 Die Casting Solutions. And the number keeps growing - we add up to 100 new die casting machines every single month, to this already impressive number. This is based on a modular machine design, an efficient best-cost supply chain, and a production environment 100% focused on quality and continuous improvement. Our large machine base provides us with ample experience to fully understand our customers' needs regarding customer service support, thus ensuring a competitive lifetime-cost of our products.

### GLOBAL SERVICE NETWORK

# 150<sup>+</sup>

Service Offices (Overseas)

# 70<sup>+</sup>

Business reaches over 70 countries and regions



Overseas technology & service centers

